

Voxx Electronics Corporation is committed to quality and customer service, and is pleased to offer you this Warranty. Please read it thoroughly and contact the Company at 1-800-323-4815 with any questions.

Who is covered? Voxx extends this warranty to the original retail purchaser of products purchased through an authorized retailer or distributor in the U.S.A., Puerto Rico or Canada. This warranty is not transferable or assignable. Proof of purchase is required in the form of an original sales receipt. Internet sales outlets are NOT Authorized retailers in most cases.

What is covered? The Company warrants that should this product or any part thereof, under normal use, be proven defective in material or workmanship within three years (36 months) from the date of original purchase, such defect(s) will be repaired or replaced with a new or reconditioned product (at the Company's option) without charge for parts and repair labor.

What is not covered? This Warranty does not cover the following:

- Damage incurred during shipping or transporting the product to the Company or a service center
- Defects in cosmetic, decorative or non-operative structural parts
- Correction of installation problems
- Costs incurred for installation, removal or reinstallation of the product
- Consequential damage to other installed accessories or vehicle electrical systems including vehicle batteries.
- Damage caused by improper installation, mishandling, misuse, neglect, accident, blown fuse, battery leakage, theft or improper storage
- Products whose factory serial number/bar code label(s) or markings have been removed or defaced
- Damage resulting from moisture, humidity, excessive temperature, extreme environmental conditions or external natural causes.

Limitations: THE EXTENT OF THE COMPANY'S LIABILITY UNDER THIS WARRANTY IS LIMITED TO THE REPAIR OR REPLACEMENT PROVIDED ABOVE AND, IN NO EVENT, SHALL THE COMPANY'S LIABILITY EXCEED THE PURCHASE PRICE PAID BY PURCHASER FOR THE PRODUCT. This Warranty is in lieu of all other express warranties or liabilities. ANY IMPLIED WARRANTIES, INCLUDING ANY IMPLIED WARRANTY OF MERCHANTABILITY, SHALL BE LIMITED TO THE DURATION OF THIS WRITTEN WARRANTY. ANY ACTION FOR BREACH OF ANY WARRANTY HEREUNDER INCLUDING ANY IMPLIED WARRANTY OF MERCHANTABILITY MUST BE BROUGHT WITHIN A PERIOD OF 36 MONTHS FROM DATE OF ORIGINAL PURCHASE. IN NO CASE SHALL THE COMPANY BE LIABLE FOR ANY CONSEQUENTIAL OR INCIDENTAL DAMAGES FOR BREACH OF THIS OR ANY OTHER WARRANTY, EXPRESS OR IMPLIED, WHATSOEVER. No person or representative is authorized to assume for the Company any liability other than expressed herein in connection with the sale of this product.

Some states do not allow limitations on how long an implied warranty lasts or the exclusion or limitation of incidental or consequential damage so the above limitations or exclusions may not apply to you. This Warranty gives you specific legal rights and you may also have other rights which vary from state to state.

Obtaining Warranty Service: To obtain repair or replacement within the terms of this Warranty, call 1-800-323-4815 for the location of a warranty station serving your area.

• You must prepay the initial shipping charges to the Company. The Company will pay the return shipping charges for all warranted products returned to an address within the U.S.A., Puerto Rico or Canada. • Please package the product securely to avoid shipping damage. We recommend using a carrier that provides tracking service to prevent lost packages. Lost or damaged packages are not covered by this warranty. • Provide a detailed description of the problem(s) for which you require service.

# Parking Assist System

## Manual

### PSB110, PSB120

VOXX Electronics Corporation  
Hauppauge, NY 11788  
Technical Assistance: 1-800-323-4815  
All rights reserved © 2014 VOXX  
Printed in China

\*Specifications subject to change without notice

### Important notice

1. This product utilizes high voltage. Any unauthorized modifications or damage to the product may result in electrical shock. Handle all components with care. Inspect regularly for damage to components and cabling.
2. You are responsible for ensuring that the installation of this product does not void or affect the vehicle manufacturer's warranty. VOXX Electronics Corporation or its subsidiaries are not liable in full or in part for improper installation resulting in loss or damage to property, or for voiding all or part of the vehicle manufacturer's warranty.
3. Do not apply excessive force to any of the components contained within this kit. Excessive force used before, during or after installation that results in a damaged or non-functional part will void all warranties.
4. Please follow the procedures in this installation manual. Improper installation or modification of this product will void all warranties.

### Disclaimer

This product is intended to assist in safe driving by signaling the driver of the distance to obstacles in close proximity to the vehicle while the vehicle is in reverse moving slowly. You, as the driver, are solely responsible for the safe operation of your vehicle and the safety of your passengers according to your local traffic regulations. Do not use any features of this system to the extent it distracts you from safe driving. Your first priority while driving should always be the safe operation of your vehicle. VOXX International Electronics Corporation cannot accept any responsibility whatsoever for accidents resulting from failure to observe these precautions or safety instructions.

### About the product

This Rear Parking Sensor System is designed to assist the driver by providing an alert when an object is behind the vehicle whenever the vehicle is shifted into reverse. Never rely solely on this product to ensure the area is clear of children and/or obstructions. This product is not intended to replace existing safety procedures, but rather to add an additional safety tool for your vehicle.

Your backup sensing system transmits and receives ultrasonic waves from the sensors mounted in your vehicle's rear bumper. As the transmitted waves bounce off obstacles behind your vehicle and are received back by the sensors, the unit's control box converts these waves into warning sounds, or beeps, which alerts you, the driver, of obstacles behind your vehicle.

### Key features

- 4 sensor system with audible buzzer or LED display
- Anti-false alert technology
- Self-test function
- All weather design

### Specifications

- Input voltage 9~16V DC
- Beep SPL 70 ~ 90 dB
- Display range 0.3 m ~ 2.5m/1 ft ~ 8.2 ft
- Buzzer range 0.3m~1.5m/1ft~4.9ft
- Sensor installation height 45 cm ~ 65 cm

### Buzzer or LED display

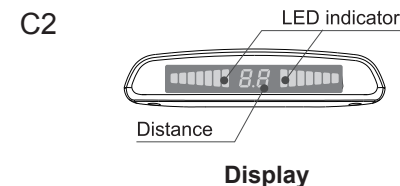
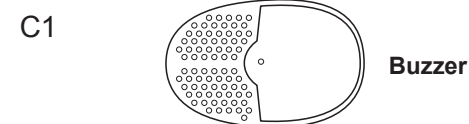

### Self-test function

#### PSB110 With Buzzer

When Reverse gear is selected, the system will automatically test each sensor each time.

- 1: If all sensors are working normally you will hear one beep.
- 2: If one or all sensors are damaged or defective you will hear 3 beeps.
- 3: If the system is non-functional you will not hear a confirmation beep.

1. All sensors are working normally

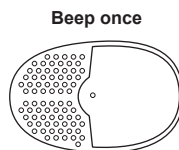

2. Damaged sensor is detected



#### PSB120 With Display

When Reverse gear is selected, the system will automatically test each sensor each time.

If all sensors are working normally you will hear one beep. If the system is non-functional you will not hear a confirmation beep. If one or all sensors are damaged or defective you will hear and see:

- Beeps three times
- The number and locations of damaged sensors are shown on the display

1. All sensors are working normally

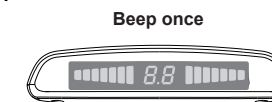

2. Damaged sensor is detected

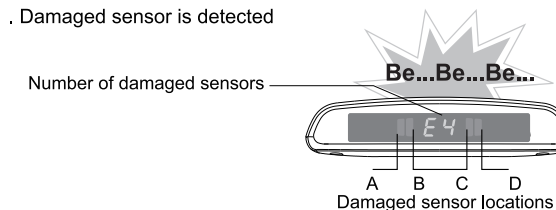

### How does the system work

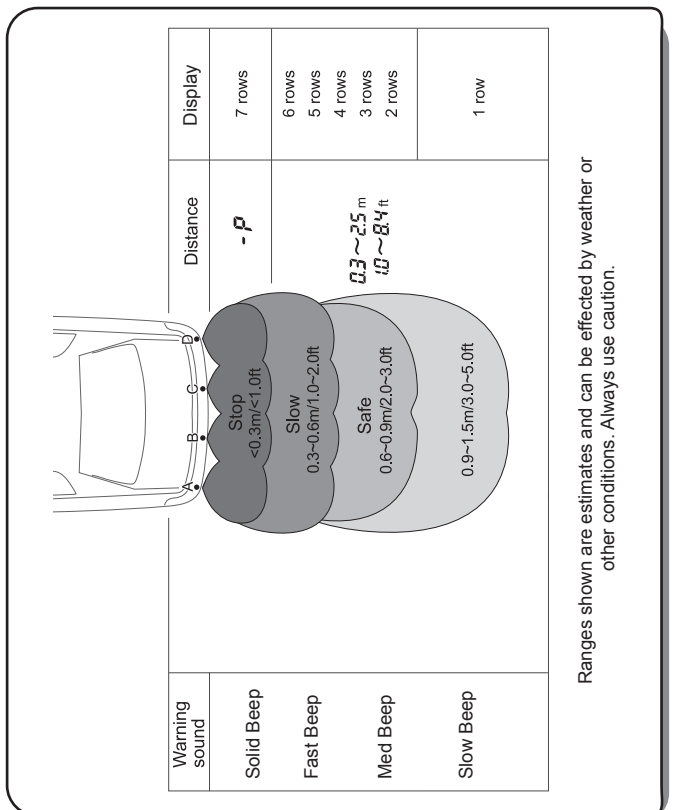

## Attention

Your system may alert to some situations and accuracy can be affected by the examples of situations below. Always use mirrors and caution when backing.

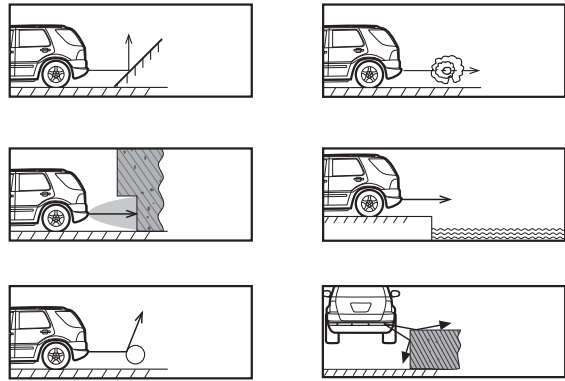

Always completely test the system after installation or modification.

Sensors that are dirty, covered with snow / ice, heavy rain, or other objects can cause false alerts or reduce sensitivity.

Do not cover sensors with paint protection film, stickers, vehicle wrap, or any other material as this will block the sensor.

If the automatic self test alerts you to a problem: STOP!, Park, Look. Seek service on the sensor system before using for parking.

## Sensor maintenance

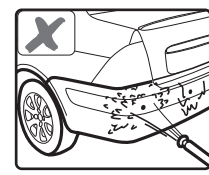

DO NOT directly spray the sensors with high pressure car wash wands.

Normal drive through car washes are OK.

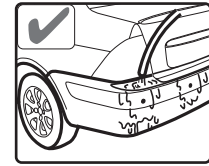

Washing your car with low pressure water and a soft sponge or cloth is always the best way to insure a clean sensor surface and best operation.

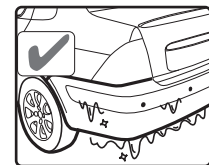

If your sensors are covered by snow and ice use warm water to melt away the ice. Do not use a scraper over the sensor surface, this could damage the sensor and effect it's operation.

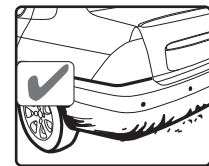

Sand, mud, and road debris should also be washed away with warm water, soap, and a soft cleaning cloth to insure the sensor surface is not damaged.

## Installation diagram

Sensors MUST be installed and plugged in as shown for correct zones

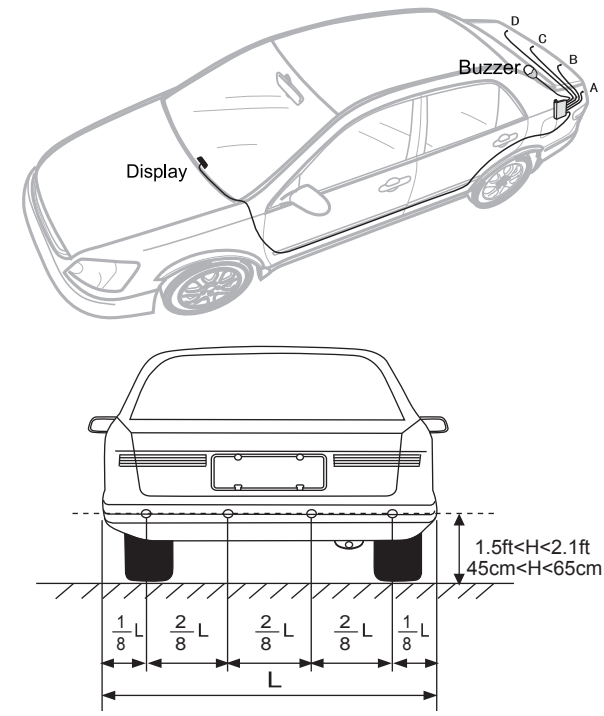

Space sensors as shown above. Even spacing will result in the best operation

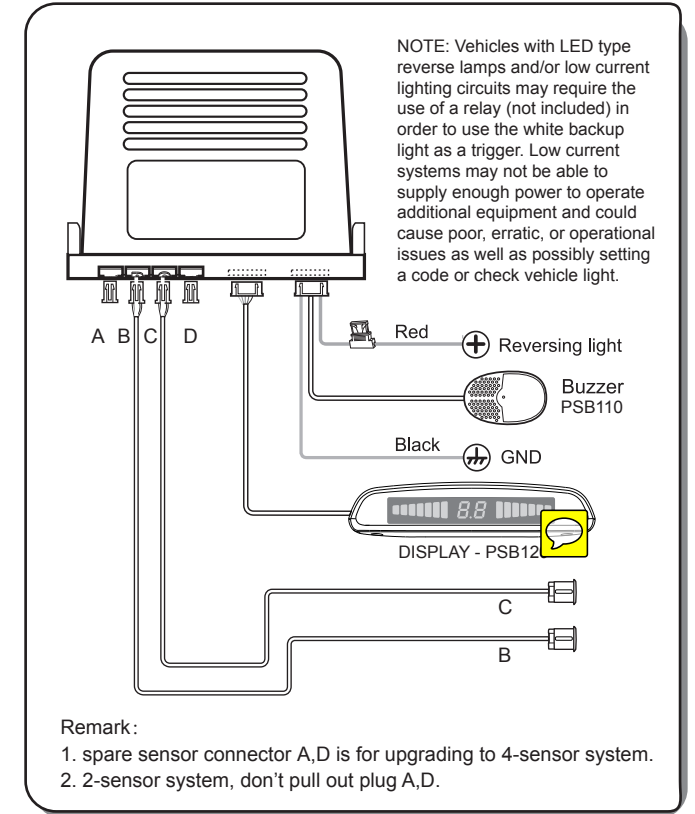

## Sensor installation

Each sensor has "UP" and an arrow on the rear of the sensor. It is important that the sensors are installed correctly and positioned with the up arrow pointing straight up. Sensors installed incorrectly may false, have reduced sensitivity, or not work at all. The sensors included in this kit are designed to be used in plastic bumper installations ONLY with the drill bit included in the kit. Installations in other materials or applications are not recommended and may result in poor operation.

BEFORE DRILLING - MEASURE, MARK, AND CHECK BEHIND THE BUMPER TO INSURE YOU DO NOT HIT ANY METAL, SENSOR, SUPPORT, OR ANY OTHER OBSTRUCTIONS.

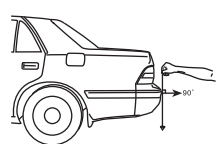

The sensor must be mounted vertical and straight for proper operation

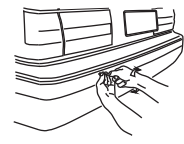

Measure the bumper for proper placement (see above), Mark location with a grease pencil. Check behind location to insure your OK to drill here.

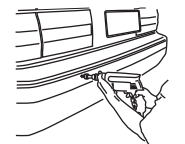

If OK use the supplied hole saw to drill your mounting hole. Use caution to not slip and scratch the bumper. TIP: Use tape around the hole to protect the paint.

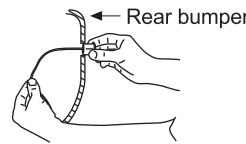

Guide the sensor wire through the hole. Insure the sensor is inserted with the arrow UP. Push firmly into the hole.

Connect the extension leads to the sensors and note A,B,C, D, for later connection. Route all wires from the sensors to the control module located in the rear of the vehicle interior. Make sure all wires are securely attached to the vehicle using wire ties and your opening into the vehicle does not have sharp edges that could damage the wires. Sensor wires CAN NOT be extended. Seal the hole entering the vehicle with a grommet or silicone. Follow the included wiring instructions to complete your installation.

## System Testing

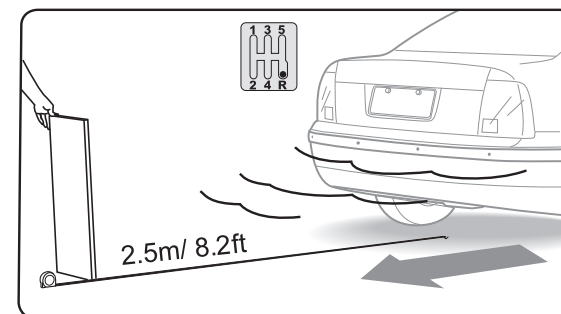

After installation is complete you should test the system. With the vehicle on a flat surface with no obstructions (not inside the shop), ignition OFF and parking brake engaged. Turn the ignition on and have someone inside the vehicle place their foot on the brake and shift the vehicle to Reverse. Stand to the side of the vehicle and place your hand over each sensor one at a time. You will hear a beep or see the display confirming operation of each sensor. Once done place the vehicle in PARK. Next using a traffic cone or board (1' x 3') placed 9 feet or more behind the vehicle, (do not stand behind the vehicle) slowly backup to the object. The sensor should give you a series of beeps increasing in speed until you reach the safety zone. The buzzer will give a solid tone: STOP. The system is working correctly if all of these tests are successful.

**NEVER STAND BEHIND A MOVING VEHICLE TO TEST SENSORS OR HOLD THE TEST OBJECT.**

## Troubleshooting

- After Installation the buzzer or display does not operate.
  - A) Check all wire connections
  - B) Make sure the vehicle ignition is on.
  - C) Is the vehicle in Reverse - White reverse lamp is on?
  - D) Is there enough current in the lamp circuit to operate the sensors? LED and low current lighting systems may require additional power and a relay.
- The system shows a damaged or non-working sensor.
  - A) Make sure all sensor connections are secure at the module.
  - B) Check to make sure all waterproof connectors at the sensors lead are correctly connected and secure.
  - C) Make sure the sensor is not covered or blocked.
  - D) Make sure that the sensor has not been damaged.
- The system instantly gives a solid or false warning.
  - A) Are all sensors connected correctly?
  - B) Is the power source / ground correct and sufficient to operate the system?
  - C) Are the sensors in correctly with UP in the correct position?
- If these problems persist:
  - A) For consumers - Please contact the installing dealer or car dealer.
  - B) Dealer/Installer
    - 1) Replace the ECU and check the system
    - 2) Repeat the system testing instructions to identify the issue.
    - 3) Replace any non-functioning sensor.

Contact VOXX Tech support at 800-323-4815 for further help.