

ADVENT

Rear Parking Sensor System

Model: PSS100

Installation Manual



TABLE OF CONTENTS

Warnings.....	2
Product Description	3
Packing List	3
Installation Instructions	4
<i>Mounting the Sensors</i>	4
<i>Installing the Power Harness</i>	7
<i>Mounting the Speaker</i>	8
<i>Mounting the Control Module</i>	9
Specifications.....	10
Maintenance.....	10
Troubleshooting.....	10
Warranty	11

Features

- Two reversing sensors detect obstacles up to 5 feet
- Upgradeable to a 4 Sensor system (requires part #: PSS200)
- Includes 0°, 4°, 8° and 16° sensor sleeves to fit most bumpers
- Activates only when vehicle is in reverse
- Will not drain battery or void factory warranty
- Includes tricolor LED/speaker display with 3 settings - high, low, and off
- Three detection zones give the following warnings:
 - 1 = slow beep within 3-5 feet
 - 2 = medium beep within 1.3-3 feet
 - 3 = steady tone within 1.3 feet
- Works with any vehicle

Warnings

This product is intended to assist in safe driving by signaling the driver of obstacles behind the vehicle while the vehicle is in reverse. You, as the driver, are solely responsible for the safe operation of your vehicle and the safety of your passengers according to your local traffic regulations. Do not use any features of this system to the extent it distracts you from safe driving. Your first priority while driving should always be the safe operation of your vehicle. Audiovox Electronics Corporation cannot accept any responsibility whatsoever for accidents resulting from failure to observe these precautions or safety instructions.

1. This product utilizes high voltage. Any unauthorized modifications or damage to the product may result in electrical shock. Handle all components with care. Inspect regularly for damage to components and cabling.
2. You are responsible for ensuring that the installation of this product does not void or affect the vehicle manufacturer's warranty. Audiovox Electronics Corporation or its subsidiaries are not liable in full or in part for improper installation resulting in loss or damage to your property, or for voiding all or part of the vehicle manufacturer's warranty.
3. Do not apply excessive force to any of the components contained within this kit. Excessive force used before, during or after installation that results in a damaged or non-functional part will void all warranties.
4. Please follow the procedures in this installation manual. Improper installation or modification of this product will void all warranties.

Product Description

This Rear Parking Sensor System is designed to assist the driver by providing an alert when an object is behind the vehicle whenever the vehicle is shifted into reverse. Never rely solely on this product to ensure the area is clear of children and/or obstructions. This product is not intended to replace existing safety procedures, but rather to add an additional safety tool for your vehicle.

Packing List

The model PSS100 Rear Parking Sensor System consists of the following items:

1. Control box with Velcro pad
2. Sensors, 2 each, with 19.68ft (6M) length of cable
3. 9.84ft (3M) power cable
4. Tricolor LED display/speaker with 9.84ft (3M) length of cable
5. 2 each of the following sensor sleeves:
 - 0°
 - 4°
 - 8°
 - 16°
6. Hardware bag includes:
 - 2 tap connectors
 - 8 cable ties
 - 1 Velcro pad (for module)
 - 1 3M sticker (for speaker/LED display)
 - 2 alcohol swab pads
 - Lock screw for LED display/speaker
 - Grounding screw/washer/ring terminal.
7. Installation Manual
8. User Manual

Installation Instructions

Before installing this product, take time to familiarize yourself with the items in the box and use the packing list to verify all parts are present.

Mounting the Sensors

Choosing the Correct Sensor Sleeve

Use the application guide below to determine whether a sensor sleeve will be required. This will affect the diameter of the hole in the bumper.

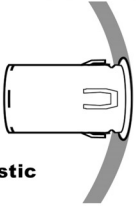
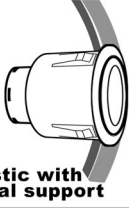
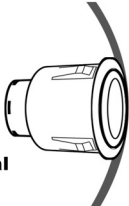
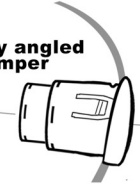
Bumper type	Bumper Angle	Supporter
 Plastic	+2° - -2°	Not required
 Plastic with metal support	+2° - -2°	Yes - 0° supporter
 Metal	+2° - -2°	Yes - 0° supporter
 Any angled Bumper	-2° - -20°	Yes use 4°, 8° or 16° supporter to ensure sensor remains horizontal

Marking and Drilling Holes

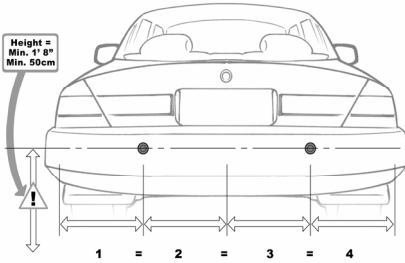

Figure 1 (2 sensors)

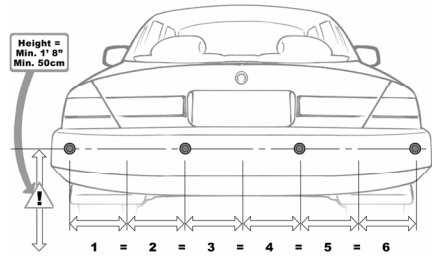

Figure 2 (4 Sensors)

1. Mark the locations of the sensors on the rear bumper using a grease pencil.
 - a) Identify the sensors' height on the bumper and mark. The sensor height should be between 18" and 30" from the ground.
 - b) Divide the bumper as shown in Figure 1 for a two sensor install or as shown in Figure 2 for a four sensor install.
 - c) Install the sensors equally from the center of the bumper, as shown in Figure 1 and Figure 2.
 - d) Inspect behind the bumper where the sensors are to be located to check for possible obstructions, including metal braces, electrical wires, and clearance. The sensors need 1.3" of clearance behind the bumper to be fully inserted and mounted securely. Do not mount sensors directly above exhaust pipes. Relocate the sensors if any obstruction exists.
2. Before drilling the holes, use a center punch to make a dimple on the bumper to prevent the drill from slipping from the intended mark.
3. Drill the sensor holes.
 - o Use a 26mm Hole Saw if you are using a sensor sleeve
 - o Use a 13/16" Hole Saw if you are installing without a sensor sleeve.
 - NOTE: Drill bits available for purchase from Audiovox.*
 - o When drilling a metal bumper, remove the sharp edges using a round metal file. Be careful not to enlarge hole when filing.

Installing the Sensor Sleeve and Sensors

NOTE: *When installing the sensors into the sensor sleeves, push on the outer ring of the sensor only. Never push on the center of the sensor.*

1. Ensure sensors and sleeves are upright (All products have an alignment mark on the top).
2. If required, install the sensor into the sleeve.
3. Install the sensor (with sleeve if required) into the holes drilled in the bumper.
4. Run the sensor wires through the sensor sleeves in the bumper.
5. Press on the outer ring of the sensor and push until the sensor is flush with the bumper. The sensor should fit snugly into the bumper and lock into place.
6. Determine where the sensor wires will enter into the trunk area or passenger compartment. Many vehicles have a factory grommet to allow routing of wires from the outside to the inside of the vehicle. If needed, drill a hole to route the wires into the vehicle, taking care when drilling metal. Smooth edges with a round metal file and use a rubber grommet to protect the wires.
7. Feed the sensor wires through the factory grommet or other opening into the vehicle for connection to the control module (e.g., into the cab of most trucks or the trunk of passenger cars).

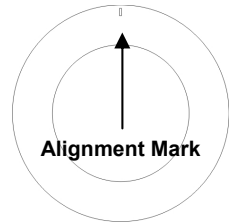

NOTE: *Once the wires are passed through, make sure there is enough wire to route to the control module. Check that the sensor wires will not be pinched by moving parts or panels.*

8. Cable tie the sensor wires and the power harness wires behind the bumper, keeping them away from the exhaust system or moving suspension parts (*install power harness before using cable ties*). Do not pull on the sensor wires near the sensor shaft exit point, as this may damage the inner connections.

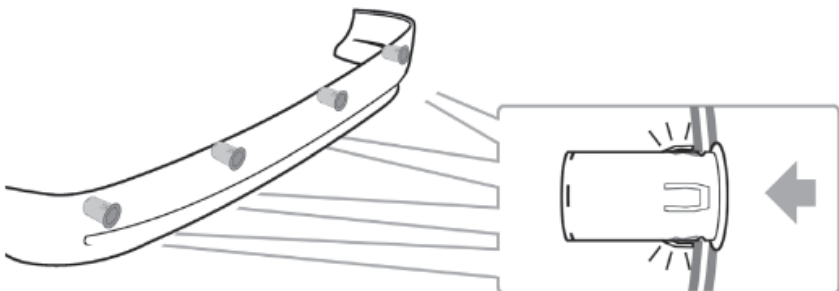

Installing the Power Harness

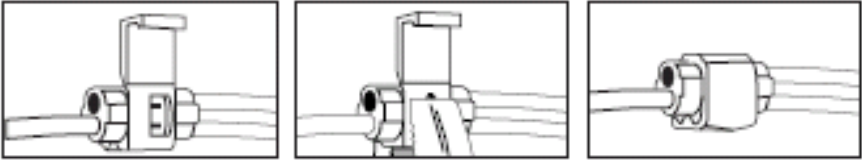

Tap/Run Connection

1. Wire the Power Harness to the vehicle's reverse lamp.
 - a) Locate the reverse lamp in the tail light assembly. Using the tap connector supplied, perform the following steps:
 - i. Place the un-stripped positive lead wire on the run channel.
 - ii. Insert the un-stripped red power wire completely.
 - iii. Make the connection between the wires by crimping down the metal connector with a pair of pliers, making sure the metal is flush with the plastic insulator.
 - iv. Close the top hinged cover until latched.
 - b) Attach the black wire to the vehicle body or to a ground wire directly attached to the vehicle body. If attaching to another wire:
 - i. Place the un-stripped ground lead wire on the run channel.
 - ii. Insert the un-stripped black ground wire completely.
 - iii. Make the connection between the wires by crimping down the metal connector with a pair of pliers, making sure the metal is flush with the plastic insulator.
 - iv. Close the top hinged cover until latched.
2. Route the power harness wires with the sensor wires to the control box.

Mounting the Speaker

The speaker has three volume settings: Off, Hi, and Low. Since the speaker can be adjusted as needed, you should mount the speaker in an accessible location in the interior. Speaker should be visible by driver, allowing them to see the LED indicators.

1. Route the wires for the speaker to the area where you will install the control module. Make sure they will not be pinched by the panel or moving parts.
2. Clean the back of the speaker and the mounting location to ensure good adhesion. When the location is dry, peel the backing strip off the Velcro tape and place on the back of the speaker. Next, peel the backing strip off the other side of the Velcro tape and press on the cleaned surface. Use the optional mounting screws (provided), if necessary.



Mounting the Control Module

Determine a dry place inside the vehicle (out of the way) to mount the control module (e.g., behind an inner body panel), making sure that all wiring will reach the intended location.

1. Plug the sensor wires, speaker and power harness into the control module before mounting. The sensor must be plugged into the corresponding socket (see Figure 4). The control module is pre-fitted with Velcro for mounting.
2. Clean the pre-selected mounting area to ensure good adhesion.
3. When the surface is dry, peel the backing off the Velcro pad and attach the control module.

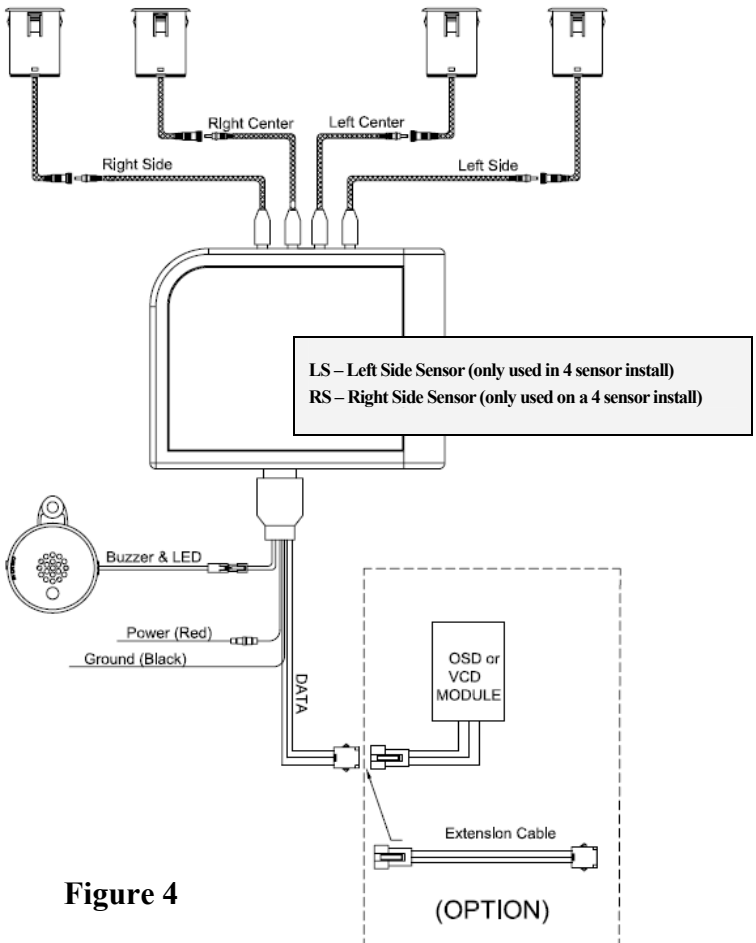

Figure 4

Specifications

Power Supply	DC9V-DC16V
Current Draw	<120mA
Detecting Distance	0ft – 5ft
Sensor Cable Length	19.68ft (6M)
Operating Temperature Range	-0°F ~ 176°F

Maintenance

Though your backup system requires minimum care, you should maintain its condition and performance using the following the guidelines:

- Keep the control box away from moisture, extreme heat or cold.
- Keep the sensors free from snow, ice, and debris.

Diagnostics / Trouble Shooting

Problem	Solution
No sound when reverse gear is engaged.	<ol style="list-style-type: none">1. Check if ignition/reverse light on2. Check power cable connection3. Check switch on speaker
1 Beep	System is functioning correctly
2 Beeps	1 sensor is disconnected/damaged
3 Beeps	2-3 Sensors are disconnected/damaged
4 Beeps	No sensors are connected
System beeping without obstacle behind vehicle	<ol style="list-style-type: none">1. Ensure sensor is mounted upright.2. Remove anything mounted on the vehicle that may be in the detection area.3. Ensure correct hole size has been drilled in bumper.4. Verify sensor is installed at the correct height.5. Verify sensor is in the correct position.6. Check all connections.7. Ensure module is not mounted near electrical components with high current.8. Verify supporter was used if required (angled/metal bumpers).



AUDIOVOX®

3 YEAR LIMITED WARRANTY

Applies to Audiovox Series Control Modules and Sensors.

AUDIOVOX Electronics Corporation (the Company) warrants to the original retail purchaser of this product that should this product or any part thereof, (other than transmitters), under normal use and conditions, be proven defective in material or workmanship within 36 months from the date of original purchase, such defect(s) will be repaired or replaced with new or reconditioned product, (at the Company's option) without charge for parts or repair labor.

To obtain repair or replacement within the terms of this Warranty, the product is to be delivered with proof of warranty coverage (e.g. dated bill of sale), specification of defect(s), transportation prepaid, to an approved warranty station. This Warranty is not assignable or transferable.

This Warranty does not cover damage to the vehicle's electrical system or costs incurred for removal or reinstallation of the product. This Warranty does not cover batteries nor apply to any product or part thereof which, in the opinion of the Company, has suffered or been damaged through alteration, improper installation, mishandling, misuse, abuse, neglect, accident, or by removal or defacement of the factory serial number/bar code label(s).

This Warranty is in lieu of all other express warranties or liabilities. ANY IMPLIED WARRANTIES, INCLUDING ANY IMPLIED WARRANTY OF MERCHANTABILITY, SHALL BE LIMITED TO THE DURATION OF THIS WRITTEN WARRANTY. ANY ACTION FOR BREACH OF ANY WARRANTY HEREUNDER INCLUDING ANY IMPLIED WARRANTY OF MERCHANTABILITY MUST BE BROUGHT WITHIN A PERIOD OF 48 MONTHS FROM THE DATE OF ORIGINAL PURCHASE. IN NO CASE SHALL THE COMPANY BE LIABLE FOR ANY CONSEQUENTIAL OR INCIDENTAL DAMAGES FOR BREACH OF THIS OR ANY OTHER WARRANTY. No person or representative is authorized to assume for the Company any liability other than expressed herein in connection with the sale of this product.

The company does not warrant that this product cannot be compromised or circumvented. THE EXTENT OF THE COMPANY'S LIABILITY UNDER THIS WARRANTY IS LIMITED TO THE REPAIR OR REPLACEMENT PROVIDED ABOVE AND, IN NO EVENT, SHALL THE COMPANY'S LIABILITY EXCEED THE PURCHASE PRICE PAID BY

Audiovox Electronics Corporation, 150 Marcus Blvd., Hauppauge, New York 11788 • 1-800-645-4994

128-7075C

© 2009 Audiovox Electronics Corp., 150 Marcus Blvd., Hauppauge, NY



For Customer Service
Visit Our Website At
www.audiovox.com
Product Information, Photos,
FAQ's Owner's Manuals