

12 MONTH LIMITED WARRANTY

Applies to Audiovox Series Collision Avoidance, Control Modules,
Sensors, Cameras, Mirrors, and Monitors

AUDIOVOX Electronics Corporation (the Company) warrants to the original retail purchaser of this product that should this product or any part thereof, under normal use and conditions, be proven defective in material or workmanship within 12 months from the date of original purchase, such defect(s) will be repaired or replaced with new or reconditioned product, (at the Company's option) without charge for parts or repair labor.

To obtain repair or replacement within the terms of this Warranty, the product is to be delivered with proof of warranty coverage (e.g. dated bill of sale), authorization number, specific cation of defect(s), transportation prepaid, to an approved warranty station. This warranty is not transferable.

This Warranty does not cover damage to the vehicle's electrical system or costs incurred for the installation, removal or reinstallation of the product. This Warranty does not cover batteries nor apply to any product or part thereof which, in the opinion of the Company, has suffered or been damaged through alteration, improper installation, mishandling, misuse, abuse, neglect, accident, or by removal or defacement of the factory serial number/bar code label(s).

This Warranty is in lieu of all other express warranties or liabilities. ANY IMPLIED WARRANTIES, INCLUDING ANY IMPLIED WARRANTY OF MERCHANTABILITY, SHALL BE LIMITED TO THE DURATION OF THIS WRITTEN WARRANTY. ANY ACTION FOR BREACH OF ANY WARRANTY HEREUNDER INCLUDING ANY IMPLIED WARRANTY OF MERCHANTABILITY MUST BE BROUGHT WITHIN A PERIOD OF 24 MONTHS FROM DATE OF ORIGINAL PURCHASE. IN NO CASE SHALL THE COMPANY BE LIABLE FOR ANY CONSEQUENTIAL OR INCIDENTAL DAMAGES FOR BREACH OF THIS OR ANY OTHER WARRANTY. No person or representative is authorized to assume for the Company any liability other than expressed herein in connection with the sale of this product.

The company does not warrant that this product cannot be compromised or circumvented. THE EXTENT OF THE COMPANY'S LIABILITY UNDER THIS WARRANTY IS LIMITED TO THE REPAIR OR REPLACEMENT PROVIDED ABOVE AND, IN NO EVENT, SHALL THE COMPANY'S LIABILITY EXCEED THE PURCHASE PRICE PAID BY PURCHASER FOR THE PRODUCT WITHOUT COST OF INSTALLATION.

Some states do not allow limitations on how long an implied warranty lasts or the exclusion or limitation of incidental or consequential damage so the above limitations or exclusions may not apply to you. This Warranty gives you specific legal rights and you may also have other rights which vary from state to state.

Audiovox Electronics Corporation, 150 Marcus Blvd., Hauppauge, New York 11788

1-800-225-6074

128-7939A

ACABSC2 - Blind Spot Camera Installation Guide

Installation Information

PROFESSIONAL INSTALLTION IS RECOMMENDED.

This camera is designed to be mounted on the vehicle. Find a location that will not obstruct any equipment on your vehicle and will allow you to safely route the power/video cable into the vehicle. Use caution to not block or obstruct airbags or any safety device.

All connections should be made inside the vehicle as the power and video connections are not waterproof.

Always check twice before drilling a hole or screwing into something to insure there is nothing behind that surface.

Connect the video output (yellow) connection to the included extension cable and route the cable to the front of the vehicle. Connect this to your monitor's rear view camera input.

Wipe clean and Dry the mounting surface for two-way tape. Adjust the camera angle/direction to optimize your view on your monitor and firmly mount Camera with two-way tape.

When using the 'flush mount' method - always double check to make sure you do not hit anything behind your mounting surface. The drill bit included is designed for plastic bumpers and trim panels. If you will be mounting this in Metal you will need a metal hold saw (NOT INCUDED). Use a 16.5 mm metal cutting hold saw if needed. It is always a good idea to cover or protect the area around your mounting location with masking tape before drilling.

Features

- A. Designed for 12V vehicle electrical system
- B. Easy Installation
- C. 150 Degree Viewing Angle
- D. Color parking auxiliary lines

Notes

- A. This is an electrical product; please use according to the relevant national standard for installation, operation and use.
- B. Suitable for 12V car electrical systems - cannot be installed on vehicle with a 24V electrical system
- C. Questions? Call VOXX Technical Support: 1-800-225-6074

Alternate Applications

The ACABSC2 Blind Stop Camera can be used for alternate applications and can be installed in various locations on the vehicle, such as:

- A. Front Facing Camera
- B. Rear Facing Camera

NOTE: White Loop-Cut to switch to non-mirror image

NOTE: Ghite Loop-Cut to turn off LEDs (Located at Camera)

Connection Diagram

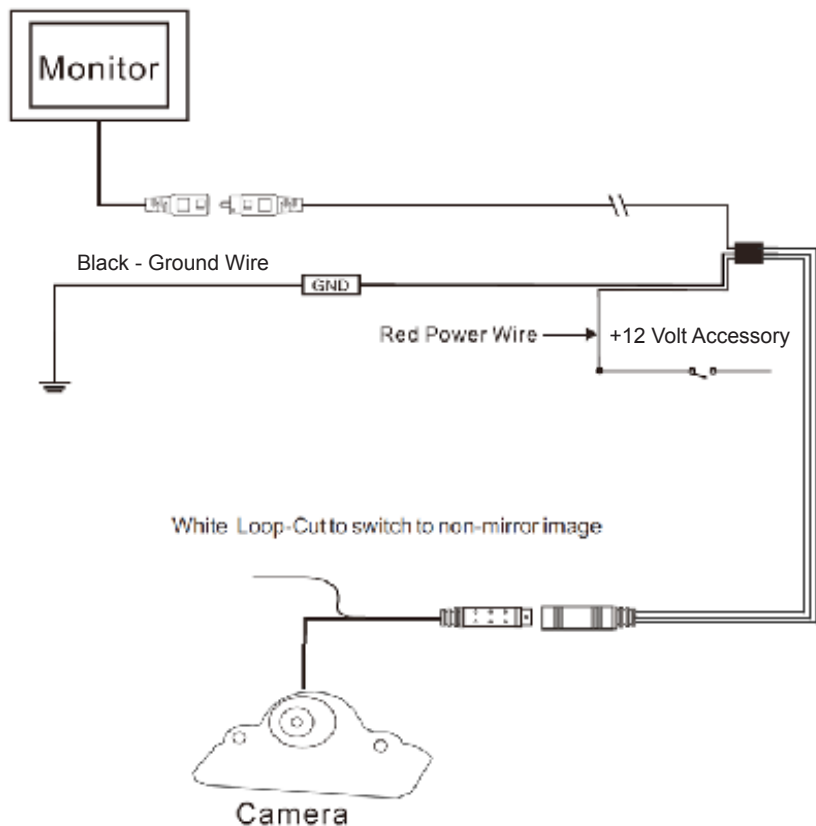

Troubleshooting

Issue	Reason	Troubleshooting
Screen Shake	Loose mount	Adjust camera's mount to secure location
No Image	Cables connection compromised	Unplug all connections and check for debris/foreign objects. Clean/clear connection and plug in cables
Blurry Screen	Camera lens is dirty	Carefully clean camera lens
Inclined Screen	Camera installed incorrectly	Adjust the camera's mount and placement

Specifications

Image Sensors	PC3089
Power Supply (DCV)	DC12V
Operating Current	≤ 75 = MA
Effective Pixels	756 X 504
Lux	≤ 0.2 LUX
Resolution	600
TV System	NTSC
Viewing angle	150°
IP Rating	IP 67
Operating Temperature (C)	-20 °C to +70 °C Rh95%