

ADVUV630



What's in the Box

ADVUV630 Head Unit
External Microphone
Parking Brake Wire
Hardware Bag
Speaker Output Harness
Power Input Harness
2 x Accessory Harness
Installation Guide

Tools and Supplies

You will need these tools and supplies to install your ADVUV630:

- Torx type, flat-head and Philips screwdrivers
- Wire cutters and strippers
- Tools to remove existing radio (screw driver, socket wrench set or other tools)
- Electrical tape
- Crimping tool
- Volt meter/test light
- Crimp connections
- 18 gauge wire for power connections
- 16 – 18 gauge speaker wire

WARNING! Never install this unit where operation and viewing could interfere with safe driving conditions.

Disconnecting the Battery

To prevent a short circuit, be sure to turn off the ignition and remove the negative (-) battery cable prior to installation.

NOTE: If the ADVUV630 is to be installed in a car equipped with an on-board drive or navigation computer, do not disconnect the battery cable. If the cable is disconnected, the computer memory may be lost. Under these conditions, use extra caution during installation to avoid causing a short circuit.

Replacing the Fuse

When replacing the fuse, use a new 15 Amp ATO replacement fuse. Using a fuse with an improper rating could damage the unit and cause a fire.

ISO-DIN Installation

This unit is designed to fit into a 2.0 DIN dashboard opening, found in many imported cars. The unit has threaded holes in the chassis side panels which may be used with the original factory mounting brackets of some Toyota, Nissan, Mitsubishi, Isuzu, Hyundai and Honda vehicles to mount the radio to the dashboard. Please consult with your local car stereo specialty shop for assistance on this type of installation.

- 1** Remove the existing factory radio from the dashboard or center console mounting. Save all hardware and brackets as they will be used to mount the new radio.
- 2** Remove the factory mounting brackets and hardware from the existing radio and attach them to the new radio.
CAUTION: Do not exceed M5 X 6MM screw size. Longer screws may damage components inside the chassis.
- 3** Place the radio in front of the dashboard opening so the wiring can be brought through the mounting sleeve. Follow the wiring diagram carefully and make certain all connections are secure and insulated with wire nuts or electrical tape. After completing the wiring connections, plug the ISO connectors into the mating sockets on the rear of the chassis. Turn the unit on to confirm operation (vehicle ignition switch must be "on"). If the unit does not operate, re-check all wiring until the problem is corrected.
- 4** Mount the new radio assembly to the dashboard or center console using the reverse procedure in step 1.

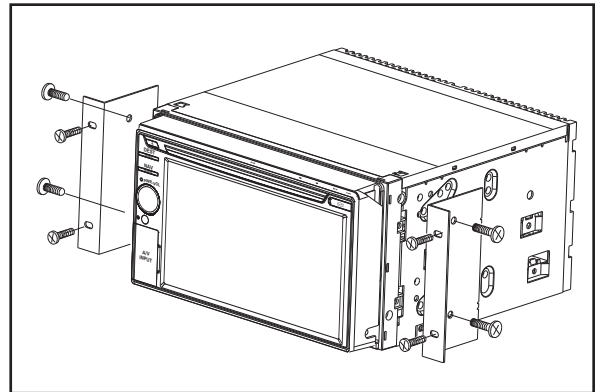

CAUTION! Be careful not to damage the car wiring.

NOTE: It is the end-users responsibility to install and operate this unit in a manner in accordance with local, state and federal laws. The PARKING BRAKE wire MUST BE CONNECTED as directed in the manual.

CAUTION: Do not block the cooling fan exit. If blocked, the unit may overheat and become damaged.

Wiring Diagram

IMPORTANT: Incorrect wiring connections can damage the unit. Follow the wiring instructions carefully, or have the installation handled by an experienced technician.

Need Help? For technical assistance, call the Jensen customer support line at 1-800-323-4815.

