

# **CODE ALARM**

## **ELITE SERIES**

---

### **Installation and Reference Guide**

---

## **ca6555E**

### **Vehicle Security, Remote Start and Keyless Entry**

# Table of Contents

<b>Before you Begin</b> .....	<b>4</b>
<b>Wire Connection Guide</b> .....	<b>5</b>
6 Pin Start Harness .....	8
22 Pin Input / Output Harness .....	10
4 Pin P.Lights / Notification Harness.....	16
3 Pin Door Lock Output Harness.....	17
<b>Additional Ports</b> .....	<b>21</b>
Antenna / LED / Programming Port.....	21
DBI Port.....	21
FLCART Cartridge Port .....	21
FLCART 4 Pin Programming Port .....	21
FLCART Harness Port.....	21
Telematic Interface Port.....	22
Digital Tilt / Shock Sensor .....	22
<b>Set Up &amp; Programming</b> .....	<b>23</b>
Transmitter Programming.....	23
Manual Feature Programming.....	24
Shock Sensor Programming, Adjustment and Testing .....	25
Programming Feature Banks .....	26
PC Based Feature Programming / Firmware Updates - (Optional).....	30
Tach Programming .....	31
Smart Tachless Mode .....	32

Continued

Chirp Delete - User Accessible.....	32
User Selectable LED .....	32
Dome Light Delay / Theater Dimming .....	33
<b>Feature Descriptions.....</b>	<b>34</b>
<b>Transmitter Button Functions .....</b>	<b>47</b>
<b>Security Trigger Zones.....</b>	<b>49</b>
<b>Remote Start Shutdown Diagnostics .....</b>	<b>49</b>
<b>System Layout.....</b>	<b>50</b>

## Before You Begin

Thank you for trusting Code Alarm products! **If you are a consumer**, please note:  
**Professional installation is strongly recommended.**

This manual assumes the installer has adequate knowledge of the following expertise, and as such, it does not cover these topics in detail:

- 12-volt electronics
- Testing and verifying circuits
- Making safe and lasting wiring connections
- Factory ignition, power, lighting, data bus and sensing systems
- Factory systems and components to avoid
- Safe wire routing, circuit protection and product placement
- Access to vehicle-specific technical information

In addition, this manual assumes the installer has the **proper tools, skill and facilities** to perform a professional installation.

**Performing an improper installation could void your vehicle warranty and/or result in damage to the vehicle or its components, improper system function, unsafe vehicle operation or physical injury.**

**If you are an authorized Code Alarm installation technician**, please use this manual as a more detailed addendum to the Installation Quick Reference Guide that accompanies the Code Alarm system. You can download a printable PDF of the quick reference guide at [voxxuniversity.com](http://voxxuniversity.com).



**Technical Support (800) 421-3209**  
or go to  
[www.voxxuniversity.com](http://www.voxxuniversity.com)

# Wire Connection Guide

## System Layout

This diagram shows the available harnesses and connections. Note that you may not use all connections in your installation.

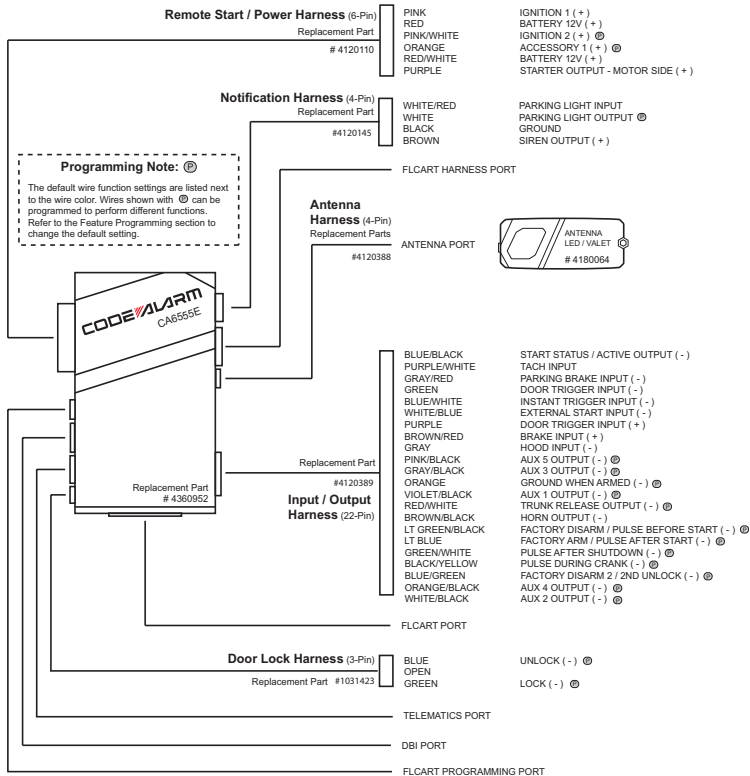

**Programming Note:** ⊕  
The default wire function settings are listed next to the wire color. Wires shown with ⊕ can be programmed to perform different functions. Refer to the Feature Programming section to change the default setting.

**Installation Note:**  
The module should be securely attached to a stable surface using zip ties in order for the on-board shock and tilt sensor to function properly.

STARTER INTERRUPT RELAY & HARNESS  
Replacement Part #1024405



ORANGE  
RED  
BLACK  
WHITE / BLACK

86 - ARMED OUTPUT (-)  
85 - IGNITION (+)  
87A - STARTER OUTPUT - MOTOR SIDE  
30 - STARTER INPUT - KEY SIDE

## 6 Pin Start Harness

6 PIN START	1	PINK	IGNITION 1 ( + )
	2	RED	BATTERY 12V ( + )
	3	PINK/WHITE	IGNITION 2 ( + )
	4	ORANGE	ACCESSORY 1 ( + )
	5	RED/WHITE	BATTERY 12V ( + )
	6	PURPLE	STARTER OUTPUT - MOTOR SIDE

## 22 Pin Input / Output Harness

22 PIN INPUT / OUTPUT	1	BLUE/BLACK	START STATUS / ACTIVE OUTPUT ( - )
	2	PURPLE/WHITE	TACH INPUT
	3	GRAY/RED	PARKING BREAK INPUT ( - )
	4	GREEN	DOOR TRIGGER INPUT ( - )
	5	BLUE/WHITE	INSTANT TRIGGER INPUT ( - )
	6	WHITE/BLUE	EXTRENAL START INPUT ( - )
	7	PURPLE	DOOR TRIGGER INPUT ( + )
	8	BROWN/RED	BRAKE INPUT ( + )
	9	GRAY	HOOD PIN INPUT ( - )
	10	PINK/BLACK	AUX 5 OUTPUT ( - )
	11	GRAY/BLACK	AUX 3 OUTPUT ( - )
	12	ORANGE	GROUND WHEN ARMED OUTPUT ( - )
	13	VIOLET/BLACK	AUX 1 OUTPUT ( - )
	14	RED/WHITE	TRUNK RELEASE OUTPUT ( - )
	15	BROWN/BLACK	HORN OUTPUT ( - )
	16	LT GREEN/BLACK	FACTORY DISARM / PULSE BEFORE START ( - )
	17	LT BLUE	FACTORY ARM / PULSE AFTER START ( - )
	18	GREEN/WHITE	PULSE AFTER SHUTDOWN ( - )
	19	BLACK/YELLOW	PULSE DURING CRANK ( - )
	20	BLUE/GREEN	FACTORY DISARM 2 / 2nd UNLOCK OUTPUT ( - )
	21	ORANGE/BLACK	AUX 4 OUTPUT ( - )
	22	WHITE/BLACK	AUX 2 OUTPUT ( - )

## 4 Pin P. Light / Notification Harness

4 PIN LIGHTS	1	WHITE/RED	PARKING LIGHT INPUT
	2	WHITE	PARKING LIGHT OUTPUT
	3	BLACK	GROUND
	4	BROWN	SIREN OUTPUT ( + )

## 3 Pin Lock Output Harness

3 PIN LOCK	1	BLUE	UNLOCK ( - )
	2	OPEN	
	3	GREEN	LOCK ( - )

## 6 Pin Start Harness

1	PINK	IGNITION 1 ( + )
---	------	------------------

Locate the vehicle's ignition wire at the ignition switch.

*Verification:* This wire registers voltage when the key is turned to the ON (or RUN) position. The voltage does not drop out when the key is turned to the START (or CRANK) position.

Connect the PINK wire to the vehicle's Ignition wire.

This wire is also used for Ignition 1 Output.

2	RED	BATTERY 12V ( + )
---	-----	-------------------

Locate 1 of the vehicle's constant 12 Volt battery wires at the ignition switch.

*Verification:* This wire will register ( + ) voltage in all positions of the ignition switch.

Connect the RED wire to the constant 12 Volt battery wire.

**NOTE:** Remove all fuses until all connections are made.

3	PINK/WHITE	IGNITION 2 ( + )
---	------------	------------------

Locate the vehicle's 2nd ignition wire at the ignition switch (if equipped).

*Verification:* This wire registers voltage when the key is turned to the ON (or RUN) position, but not the ACC (Accessory) position. The voltage does not drop out when the key is turned to the START (or CRANK) position.

Connect the PINK/WHITE wire to the vehicle's ignition 2 wire.

**Programmable output:** IGN, ACC, Start.

4	ORANGE	ACCESSORY 1 ( + )
---	--------	-------------------

Locate the vehicle's accessory wire at the ignition switch.

*Verification:* This wire registers voltage when the key is turned to ACC (Accessory) and the ON (or RUN) position. The voltage drops out when the key is turned to the START (or CRANK) position.

Connect the ORANGE wire to the vehicle's accessory wire.



5 RED/WHITE

BATTERY 12V ( + )

Locate 1 of the vehicle's constant 12 Volt battery wires at the ignition switch.

*Verification:* This wire will register ( + ) voltage in all positions of the ignition switch.

Connect the RED/WHITE wire to the constant 12 Volt battery wire.

**NOTE:** Remove all fuses until all connections are made.

6 PURPLE

STARTER OUTPUT ( + )

Locate the vehicle starter wire.

*Verification:* This wire registers voltage *only* when the key is turned to the START position. Cut the vehicle's starter wire in half when installing the starter kill relay.

*Verification after starter wire is cut:*

KEY SIDE of starter wire registers voltage when the key is turned to the START position.

MOTOR SIDE of starter wire registers no voltage.

Connect the PURPLE wire to the vehicle starter wire, use the MOTOR SIDE of the vehicle starter wire when installing the starter kill relay.

## 22 Pin Input / Output Harness

1	BLUE/BLACK	START STATUS / ACTIVE OUTPUT ( - )
---	------------	------------------------------------

This wire provides a ( - ) 200mA output when the remote start function is activated and remains until 4 seconds after the remote start is shutdown. If this wire will be used for multiple application's a 1 amp diode is required in-line with the stripe facing the control module.

2	PURPLE/WHITE	TACH INPUT
---	--------------	------------

Locate the vehicle's ignition coil or fuel injector in the engine compartment.

*Verification:* Test using the following procedure:

1. Set voltmeter to AC VOLTS.
2. Attach positive lead of a volt meter to a constant 12 volt source.
3. Attach negative lead of a volt meter to the wire to be tested.
4. Start the engine.
5. Have someone press on the gas pedal slightly as you monitor the meter. If connected to the correct wire, the voltage reading will increase as the engine's RPM increases.

Connect the PURPLE/WHITE wire to the negative side of the vehicle ignition coil or fuel injector.

3	GRAY/RED	PARKING BRAKE INPUT ( - )
---	----------	---------------------------

Locate the vehicle's parking brake wire.

*Verification:* This wire will register ground when the vehicle's PARKING BRAKE is engaged.

NOTE: The following connection is required for Manual Transmission Mode.

4	GREEN	DOOR TRIGGER INPUT ( - )
---	-------	--------------------------

Locate the vehicle's dome light or door pin switch wire.

*Verification:* This wire will register ground (NEG) when the door is opened and the interior light is on. This wire will register positive voltage when the door is closed and the interior light is off.

Connect the GREEN wire to the vehicle's negative door input wire(s).

**NOTE:** Certain vehicles may require multiple connections. Refer to vehicle application guide.

5	BLUE/WHITE	INSTANT TRIGGER INPUT ( - )
---	------------	-----------------------------

This wire is a GROUND input for an external sensor or secondary pin switch.

*Verification:* This wire when connected will trigger the security system.

6	WHITE/BLUE	EXTERNAL START INPUT ( - )
---	------------	----------------------------

This wire will activate the Remote Start function when a GROUND pulse is applied to it from an external device.

7	PURPLE	DOOR TRIGGER INPUT ( + )
---	--------	--------------------------

Locate the vehicle's dome light or door pin switch wire.

*Verification:* This wire will register positive voltage (POS) when the door is opened and the interior light is on. This wire will register ground or "0" Volts when the door is closed and the interior light is off.

Connect the PURPLE wire to the vehicle's positive door input wire(s).

**NOTE:** Certain vehicles may require multiple connections. Refer to vehicle application guide.

8	BROWN/RED	BRAKE INPUT ( + )
---	-----------	-------------------

Locate the vehicle's brake light wire at the brake pedal mounted switch. This connection is required for remote start.

*Verification:* This wire registers positive voltage when the brake pedal is pressed.

Connect the BROWN/RED wire to the vehicle's brake light wire.

9	GRAY	HOOD PIN INPUT ( - )
---	------	----------------------

Install a Hood Pin Switch and connect to the GRAY wire. This connection is required for Remote Start.

*Verification:* This wire when connected will register ground when the vehicle's hood is opened.

Connect the GRAY wire to the hood pin.

**NOTE:** Be sure to loom the wire, and seal the grommet.

10	PINK/BLACK	AUX 5
----	------------	-------

This wire provides a ( - ) 200mA output capable of driving relays. For Control of optional accessories (i.e. Power Window/Sunroof, etc.).

To activate refer to the transmitter button configuration chart. Please refer to the selectable options for timing.

11	GRAY/BLACK	AUX 3
----	------------	-------

This wire provides a ( - ) 200mA output capable of driving relays. For Control of optional accessories (i.e. Power Window/Sunroof, etc.).

To activate refer to the transmitter button configuration chart. Please refer to the selectable options for timing.

12	ORANGE	GROUND WHEN ARMED OUTPUT ( - )
----	--------	--------------------------------

This wire will have a continuous ( - ) 500mA output when the system is Armed. This wire is typically used for controlling the starter interrupt relay as well as window modules or additional sensors.

This output can be configured in option programming.

13 VIOLET/BLACK

AUX 1

This wire provides a ( - ) 200mA output capable of driving relays. For Control of optional accessories (i.e. Power Window/Sunroof, etc.).

To activate refer to the transmitter button configuration chart. Please refer to the selectable options for timing.

14 RED/WHITE

TRUNK RELEASE OUTPUT ( - )

Locate the vehicle's trunk release wire at the trunk release switch.

*Verification:* This wire will register either positive voltage or ground when the trunk release is activated.

This wire will supply a ( - ) 200mA output and can be configured in option programming.

15 BROWN/BLACK

HORN OUTPUT ( - )

Locate the vehicle's horn wire.

*Verification:* This wire will register at positive voltage and register ground when the horn switch is pressed.

Connect the BROWN/BLACK wire to the vehicle's horn wire. This is a low current output, 200mA.

16 LT GREEN/BLACK

FACTORY DISARM /  
PULSE BEFORE START ( - )

This wire will supply a ( - ) 200mA pulse both upon disarming the system and when the remote start feature is activated. Locate the factory perimeter alarm disarm wire from the key cylinder inside the drivers door.

*Verification:* This wire registers ground if the key is turned to the unlock position in the driver's door cylinder.

Connect the LIGHT GREEN/BLACK wire to the factory alarm disarm wire.

17 LT BLUE

FACTORY ARM /  
PULSE AFTER START ( - )

This wire will supply a ( - ) 200mA pulse both upon arming the system and upon successful completion of the remote start activation sequence and is typically used to re-lock the vehicle's doors upon remote start if necessary.

This output can be configured in option programming.

18 GREEN/WHITE

PULSE AFTER SHUTDOWN ( - )

This wire will supply a ( - ) 200mA pulse after the remote start shuts down. This is typically used to re-lock the vehicle's doors if they unlock upon remote start shutdown. It can also be used to pulse a door pin-switch wire to prevent the vehicle's accessories from remaining on after remote start shutdown.

This output can be configured in option programming.

19 BLACK/YELLOW

PULSE DURING CRANK ( - )

Locate the vehicle's second starter (crank) wire at the ignition switch. (if equipped)

*Verification:* This wire registers voltage only in the start (crank) position of the ignition switch.

This wire will supply a ( - ) 200mA output and can be configured in option programming.

20 BLUE/GREEN

FACTORY DISARM 2

This wire will supply a ( - ) 200mA pulse both upon disarming the system and when the remote start feature is activated. Locate the factory perimeter alarm disarm wire from the key cylinder inside the drivers door.

*Verification:* This wire registers ground if the key is turned to the unlock position in the driver's door cylinder.

This output can also be configured in option programming as a 2nd Unlock output.

21	ORANGE/BLACK	AUX 4
----	--------------	-------

This wire provides a ( - ) 200mA output capable of driving relays. For Control of optional accessories (i.e. Power Window/Sunroof, etc.).

To activate refer to the transmitter button configuration chart. Please refer to the selectable options for timing.

22	WHITE/BLACK	AUX 2
----	-------------	-------

This wire provides a ( - ) 200mA output capable of driving relays. For Control of optional accessories (i.e. Power Window/Sunroof, etc.).

To activate refer to the transmitter button configuration chart. Please refer to the selectable options for timing.

## 4 Pin Light Harness

1	WHITE/RED	PARKING LIGHT INPUT
---	-----------	---------------------

2	WHITE	PARKING LIGHT OUTPUT
---	-------	----------------------

Locate the parking light output wire at the vehicle's light switch.

*Verification:* This wire registers positive voltage when the parking lights are turned on.

Positive switching Parking Lights:

Connect the WHITE/RED wire to a 15 Amp max fused battery source.

Connect the WHITE wire to the parking light output wire.

Negative switching Parking Lights:

Connect the WHITE/RED wire to a good chassis ground.

Connect the WHITE wire to the parking light output wire.

3	BLACK	GROUND
---	-------	--------

Connect the BLACK wire to a solid chassis ground point using a ring terminal and self tapping screw (not supplied). Scrape away paint from the grounding point to ensure a good connection. The recommended grounding point is a metal surface in the driver's side kick panel area.

**NOTE:** Do not ground the BLACK wire with any other vehicle components.

4	BROWN	SIREN OUTPUT ( + )
---	-------	--------------------

Locate a suitable mounting location in the engine compartment for the siren, away from moving parts.

With the bell of the siren aiming downwards, secure the siren in place using self tapping screws, being careful not to drill into any hoses, wiring or components.

Connect the BLACK siren wire to a chassis ground using a ring terminal and self tapping screw (not supplied).

Route the BROWN siren output wire from the control module through the firewall and connect to the RED wire on the siren.

**NOTE:** Be sure to loom the siren wires, and seal the grommet.



## 3 Pin Lock Output Harness

1	BLUE	UNLOCK ( - )
---	------	--------------

3	GREEN	LOCK ( - )
---	-------	------------

The door lock / unlock outputs are designed to control several different types of systems which may require additional parts. Please review the wire and location chart to see which type of door lock system is in your vehicle. The most common types are shown in the following diagrams.

These wires supply a ( - ) 500mA output.

### Negative Switching Locks

All Door Lock and Unlock: Locate the lock / unlock wire at the vehicle's lock / unlock switch.

*Verification:* These wires will register ground when the Lock and Unlock switches are activated.

Connect the GREEN and BLUE wires shown in the diagram below.

### Negative Locks:

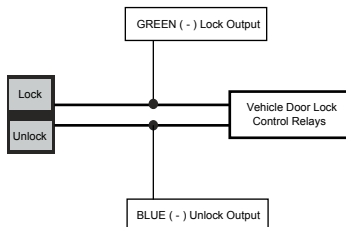

## Positive Switching Locks

All Door Lock and Unlock: Locate the lock / unlock wire at the vehicle's lock / unlock switch.

*Verification:* These wires will register positive voltage when the Lock and Unlock switches are activated.

Connect the GREEN and BLUE wires shown in the diagram below.

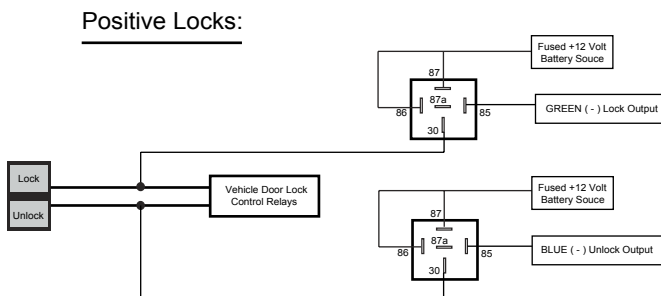

## Reverse Polarity Locks (5-Wire Door locks)

All Door Lock and Unlock: Locate the lock / unlock wire at the vehicle's lock / unlock switch.

*Verification:* These wires will rest at ground and register positive voltage when the Lock and Unlock switches are activated.

Connect the GREEN and BLUE or BLUE/GREEN wires shown in the diagram below using (2) SPDT relays (not supplied).

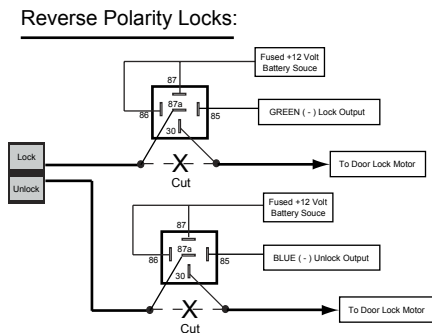

## Negative Multiplexed Locks

All Door Lock and Unlock: Locate the lock / unlock wire at the vehicle's lock / unlock switch.

*Verification:* This wire will show variable ground when the switch is activated. Please consult the wire and location chart for specific resistor values for your vehicle.

Connect the GREEN and BLUE or BLUE/GREEN wires shown in the diagram below using (2) SPDT relays (not supplied).

### Multiplex Locks:

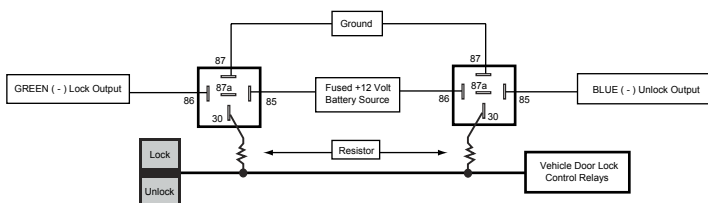

## Positive Multiplexed Locks

All Door Lock and Unlock: Locate the lock / unlock wire at the vehicle's lock / unlock switch.

*Verification:* This wire will show variable positive voltage when the switch is activated. Please consult the wire and location chart for specific resistor values for your vehicle.

Connect the GREEN and BLUE or BLUE/GREEN wires shown in the diagram below using (2) SPDT relays (not supplied).

### Multiplex Locks:

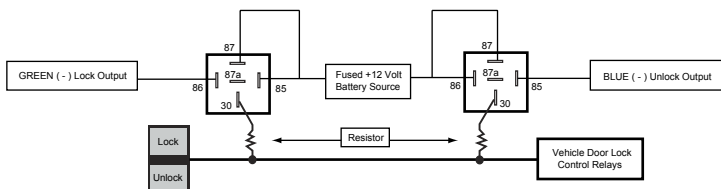

## Adding Aftermarket Actuators

After installing aftermarket actuators, (not supplied). Connect the GREEN and BLUE wires shown in the diagram below using (2) SPDT relays (not supplied).

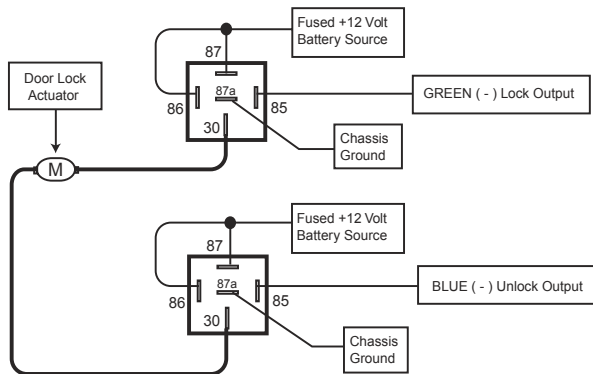

## Additional Ports

### Antenna / LED / Programming Port

Mount the antenna/receiver to a clear spot on the vehicle's windshield that will not block the driver's vision. A good location is usually high on the windshield near the rear view mirror. Be careful not to mount the antenna/receiver on any metallic window film, as this will effect system range. Route the antenna/receiver cable to the control module and plug into the antenna port.

### DBI Port - 4 Pin Data Bus Interface

The DBI port is used for external Flashlogic data immobilizer & door lock Interface modules to communicate with the vehicle's databus. When using the DBI port to control Flashlogic modules please refer to the D2D (Data to Data) function list available per vehicle firmware on the tech service web site.

**NOTE: Flashlogic modules sold separately.**

### FLCART Cartridge Port

This port is for installing the Flashlogic FLCART data immobilizer & door lock interface cartridge used to communicate with the vehicle's databus.

**NOTE: FLCART sold separately.**

### FLCART 4 Pin Programming Port

This 4 port is used for programming the Flashlogic FLCART interface cartridge via the FLPROG Weblink Updater. Refer to the Flashlogic website for more details.

**NOTE: FLCART sold separately.**

### FLCART Harness Port

This port is for the harness included with the FLCART interface cartridge. Refer to the Flashlogic website for more details.

**NOTE: FLCART sold separately.**

## Telematic Interface Port

This 4 pin port is used for CarLink telematic accessories which can control some of the following features.

Door Lock Control	Trunk Release
Sliding Doors	AUX Output
Car Find	Remote Start

## Digital Tilt / Shock Sensor

The systems digital tilt and shock sensor is onboard and part of the main module. Mount the module to a firm wire harness, or other stable location, that will allow the sensor to pick up vibrations due to impact to the vehicle or if the vehicle is lifted / tilted.

When the security system is armed a light impact to the vehicle will trigger the system's warn-away feature chirping the horn/siren several short times, a harder impact will trigger the system's full-trigger mode.

To adjust the shock sensor, refer to **Shock Sensor Programming, Adjustment and Testing**.

To adjust the tilt sensor, refer to **Digital Tilt Setting** in option programming.

**NOTE:** During remote start, the system will ignore the sensor upon ignition until after remote start shutdown.

### Transmitter Programming - Feature Bank 1

1. Turn the ignition ON.
2. Press and hold the valet/override button.
3. Within 10 seconds the system will chirp (3) three times.
4. Press 1 button of each transmitter you wish to program.
5. The system will respond with 1 chirp for each accepted transmitter.
6. Pressing the override button at anytime during programming will advance to the next bank.

**NOTE:** The system will exit transmitter programming after 15 seconds of inactivity.

**NOTE:** This system has 1 button programming which programs all channels of the system.

**NOTE:** The system will hold up to 4 transmitters in memory, programming a 5th transmitter will erase the oldest transmitter in memory.



**NOTE:** This system has PTN - Programmed Transmitter Notification. Each time the ignition is turned ON, the LED will flash the number of transmitters programmed to the system.

#### **Transmitter programming for 2 Car Mode \*2 way system only:**

1. Enter the transmitter into 2 Car Mode. (Refer to transmitter operation in the owners manual for 2 car operation)
2. Follow the steps above for transmitter programming.

**NOTE:** 2 car mode requires an additional security system installed in a second vehicle.

## Manual Feature Programming - Feature Bank 2, 3, 4, & 5

1. Turn the ignition ON.
2. Press and hold the valet/override button.
3. Within 10 seconds the system will chirp (3) three times.
4. Use the valet/override button to advance through each option bank. For feature programming advance to Feature Bank 2, 3, 4 or 5, which is (4) four, (5) five, (6) six and (7) seven chirps.
5. Use the transmitter  button to scroll through the selections in each feature bank, the system will chirp to match the feature number.
6. Press the transmitter  button (or the vehicle's brake pedal) to change the desired feature. The LED will flash indicating the changed feature.

**Defaulting All Features:** Pressing the  button anytime while in any of the feature banks will default all features and return you to feature bank 2 - 4 chirps.

**NOTE:** The system will remain in feature programming mode as long as the ignition is on, there is no time limit. To exit programming turn the IGNITION OFF.



## Shock Sensor Programming, Adjustment and Testing - Feature Bank 6

1. Turn the ignition ON.
2. Press and hold the valet/override button.
3. Within 10 seconds the system will chirp (3) three times.
4. Use the valet/override button to advance through each option bank. For Shock Sensor Adjustment advance to Feature Bank 6, which is (8) eight chirps.
5. Turn the ignition OFF, exit the vehicle and close all doors.
6. Select Auto-Learning or Manual Adjustment:

### Option (a) Auto-Learning

- a1. Press and hold the transmitter Start button until the system emits 2 long chirps to enter Shock Sensor Auto-Learning Mode.
- a2. Strike the vehicle to set the level intended for the system to trigger.
- a3. The system will store the setting, chirp 1 time and automatically advance to step 7, Manual Adjustment and Testing.

### Option (b) Manual Adjustment

- b1. Press and hold the transmitter FIND button until the system emits 1 long chirp to advance to step 7, Manual Adjustment and Testing.
7. Manual Adjustment and Testing. Adjustment and testing can be performed at any time during this step. During testing 3 short chirp indicates warn-away, 1 long chirp indicates full trigger. Allow 3 seconds between each adjustment/test.
  - a. Full trigger – Press the transmitter LOCK button to increase sensitivity. Press the UNLOCK button to decrease sensitivity.
  - b. Warn-Away – Press the FIND Button to increase sensitivity. Press the START button to decrease sensitivity.
8. Programming will exit by turning the ignition ON or if there is no activity for 60 seconds. The system will flash the parking lights 3 times to confirm exit.

**Note:** Sensitivity ranges from 0 (OFF) – 27 (most sensitive), the default setting is 4. The system will chirp when sensitivity is raised or lowered with 2 chirps indicating the highest or lowest setting.

**Defaulting the Shock Sensor:** Enter Feature Bank 6, step 6 and press and hold the UNLOCK button for 3 seconds, the system will emit 1 long chirp to confirm reset and will return to step 6. Continue with step 6 or exit programming.

**Feature Bank 1 - 3 Chirps  
Transmitter Programming**

Refer to transmitter programming.

	<b>Feature Bank 2 - 4 Chirps Security Control</b>	<b>1 LED Flash</b>	<b>2 LED Flash</b>	<b>3 LED Flash</b>	<b>4 LED Flash</b>	<b>5 LED Flash</b>	<b>6 LED Flash</b>
1	Silent Choice	ON	OFF				
2	Door Locks	Active	Passive				
3	System Arming	Active	Passive				
4	System Notifications	Siren & Horn	Siren Only	Horn Only			
5	Alarm Duration	30 Seconds	60 Seconds				
6	Security	ON	OFF	ON w/ OEM Remote Start			
7	Anti-Hijack Mode	OFF	ON				
8	Ground While Armed Orange (-) Output	Ground While Armed	Ground While Disarmed				
9	DBI Port Protocol / Telematic Port Protocol	DBI / Voxx Telematic	ADS / Voxx Telematic	DBI / ADS Telematic	ADS / ADS Telematic		
10	Arm / Disarm Chirps	Standard: 2 - Arm 1 - Disarm	Inverted: 1 - Arm 2 - Disarm				
11	LED Indicator	ON	OFF				
12	Auto Re-lock	OFF	Lock Only	Arm & Lock			
13	Extended Parking Lights	OFF	After Unlock	After Lock	After Lock & Unlock		
14	Parking Light Relay / Trunk (-) Output	Standard	Inverted				
15	Digital Tilt Sensor	3 Degrees of Tilt	1 Degree of Tilt	OFF			

**Feature Bank 2, Programming Update Notice:** Firmware version 3.0 or later.

Feature #9 has been updated to DBI Port Protocol & Telematic Port Protocol which now includes a selection for the telematic port protocol. The new default setting of **DBI / ADS Telematic** is the correct protocol setting for the ASCL6 CarLink device.

	<b>Feature Bank 3 - 5 Chirps Output Control</b>	<b>1 LED Flash</b>	<b>2 LED Flash</b>	<b>3 LED Flash</b>	<b>4 LED Flash</b>	<b>5 LED Flash</b>	<b>6 LED Flash</b>
1	Lock / Unlock Timing	<b>1 Sec.</b>	3.5 Sec.	1 Sec. Lock, 2x Unlock	30 Sec. Lock, 2x Unlock	2x Lock, 1 Sec. Unlock	0.5 Sec.
2	Factory Disarm 2 Blue / Green Output	<b>Factory Disarm</b>	2nd Unlock	Factory Disarm 2x 500mS	Factory Disarm 350mS	Factory Disarm 500mS	Factory Disarm w/ Unlock Timing
3	Ignition Locks	<b>OFF</b>	Lock / Unlock	Lock Only	Unlock Only		
4	Trunk Output Timing	<b>1 Sec.</b>	10 Sec.	20 Sec.	Latched until IGN ON	Latched ON until Button Press	
5	Hom Output Timing	<b>16mS</b>	10mS	30mS	40mS	50mS	
6	Real Panic	<b>ON</b>	OFF				
7	AUX 1 Violet / Black Output	<b>1 Sec.</b>	Latched	Latched until IGN ON	Dome Light Output	Defrost Output Single Pulse After Start	Defrost Output Latched 5 Min After Start
8	AUX 2 White / Black Output	<b>1 Sec.</b>	Latched	Latched until IGN ON	10 Sec. w/ Arm	10 Sec. w/ Disarm	L.E.D. Output
9	AUX 3 Gray / Black Output	<b>1 Sec.</b>	Latched	Latched until IGN ON	10 Sec. w/ Arm	10 Sec. w/ Disarm	L.E.D. Output
10	AUX 4 Orange / Black Output	<b>1 Sec.</b>	Latched	Latched until IGN ON	10 Sec. w/ Arm	10 Sec. w/ Disarm	L.E.D. Output
11	AUX 5 Pink / Black Output	<b>1 Sec.</b>	Latched	Latched until IGN ON	10 Sec. w/ Arm	10 Sec. w/ Disarm	L.E.D. Output

	<b>Feature Bank 4 - 6 Chirps Remote Start Control</b>	<b>1 LED Flash</b>	<b>2 LED Flash</b>	<b>3 LED Flash</b>	<b>4 LED Flash</b>	<b>5 LED Flash</b>	<b>6 LED Flash</b>
1	RS Confirmation Chirp	<b>ON</b>	OFF				
2	Run Time	<b>15 Minutes</b>	5 Minutes	10 Minutes	20 Minutes	45 Minutes	60 Minutes
3	Running Lights	<b>Steady</b>	Flashing				
4	Tach Mode	<b>Tach</b>	Tachless	Hybrid	DBI Port		
5	Voltage Level	<b>High</b>	Low				
6	Crank Time	<b>1.0 Seconds</b>	0.8 Seconds	1.5 Seconds	2.0 Seconds	4.0 Seconds	
7	Crank Output	<b>Averaging</b>	Preset Time				
8	Diesel Delay	<b>OFF</b>	10 Sec. Delay	15 Sec. Delay	20 Sec. Delay	45 Sec. Delay	
9	Remote Start Activation	<b>2x Start</b>	1x Start				
10	Ignition 2 Output Pink / White	<b>Ignition</b>	Accessory	Start / Crank			
11	Auto Start Interval	<b>3 Hour</b>	2 Hour				
12	Turbo Timer	<b>OFF</b>	1 Minute	3 Minute	5 Minute		
13	Transmission Mode	<b>Automatic</b>	Manual				
14	Temperature Start	<b>OFF</b>	14F	5F	-4F		
15	Accessory Output Orange	<b>Accessory</b>	Ignition	Start / Crank			
16	Pulse Outputs with Unlock	<b>OFF</b>	IGN, ACCY, GWR	IGN, ACCY, GWR - Pulse After Shutdown			
17	RS Door Lock Control	<b>OFF</b>	Unlock before Start, Lock After Start	Unlock Before Start	Lock After Start	Lock After Shutdown	

<b>Feature Bank 5 - 7 Chirps Alternate Output Control</b>		1 LED Flash	2 LED Flash	3 LED Flash	4 LED Flash	5 LED Flash	6 LED Flash
1	Factory Disarm Lt Green / Black Output	<b>Pulse Before Start / During Unlock</b>	Ground While Running	Ignition	Accessory	Pulse During Crank	Pulse Before Start / During Unlock - Uses Unlock Timing
2	Factory Arm Lt Blue Output	<b>Pulse After Start / During Lock</b>	Ground While Running	Ignition	Accessory	Pulse During Crank	Pulse After Start / During Lock - Uses Lock Timing
3	Pulse After Shutdown Green / White Output	<b>Pulse After Shutdown</b>	Ground While Running	Ignition	Accessory	Pulse During Crank	Pulse After Shutdown 2 Sec. Delay
4	Pulse During Crank Black / Yellow Output	<b>Pulse During Crank</b>	Ground While Running	Ignition	Accessory	Pulse Before Start / During Unlock	Pulse Before Start / During Unlock - Uses Unlock Timing

<b>Feature Bank 6 - 8 Chirps Shock Sensor Adjustment</b>	
Refer to section - Shock Sensor Adjustment	

## **Code Alarm Utility App**

### **Feature Programming / Firmware Updates (optional)**

The new Code Alarm Utility App is able to set feature options, save frequently used feature configurations as well as update module firmware.

#### **PC System Requirements:**

Windows XP SP3 or above

Min 1GB RAM

Net Framework 4.0 or above

Screen Resolution - Suggested 1280x1024 or above

#### **Required Accessory & PC Software:**

VEPROG Programmer Accessory

CA Utility App

VEPROG drivers

#### **Download and Install the Required Drivers:**

1. To download the Code Alarm Utility App visit the Voxx University website at [voxxuniversity.com](http://voxxuniversity.com) (registration/login required).
2. Select VOXXTECH and locate the utility app under the heading Software Downloads.
3. The Code Alarm Utility App download includes both the CA Utility app and necessary VEPROG drivers.
4. Install both items before attempting to update modules.

#### **Use a PC and VEPROG tool for Feature Programming or Firmware Updates:**

1. Launch the Code Alarm Utility App.
2. Connect the VEPROG to your PC via the USB port.
3. Connect the VEPROG to the Code Alarm Module.
4. Select the features you wish to change or update firmware if needed.

## Tach Programming

**The remote start will not operate unless the tach is programmed or a tachless option is turned ON.** The default method set for Tach Mode in the feature programming banks for confirming that the engine is running is "Tach". This method monitors the PURPLE/WHITE tach input wire. If an attempt is made to start the vehicle via the remote start without first programming tach, the unit will flash the parking lights 7 times indicating tach has not been learned and stored.

The Remote Start unit will learn the tach rate of most vehicle's single coil, multiple coil packs, or single injector. There are 2 methods for learning the vehicle's tach rate, to learn tach follow one of the methods below:

### Standard:

1. Turn the ignition key to the ON position.
2. Press and release the valet/override button 3 times.
3. Immediately turn the ignition key OFF.
4. Press and hold the valet/override button, then start the vehicle using the key.
5. When the unit senses the tach signal, the parking lights will begin to flash.
6. Allow the vehicle to settle to a normal idle speed.
7. Release the valet/program push-button switch. The parking lights will turn on for 2 seconds and 1 long chip will indicate that the learned tach signal is stored, and the unit has exited tach learn mode.

### Without valet/override button using the Factory Remote w/Flashlogic Interface or CarLink Device:

1. Start the vehicle's engine leaving the ignition key in the On/Run position.
2. Press and hold the brake pedal.
3. Lock the system using either the Factory Remote/Flashlogic Interface or CarLink device. The system must see the lock input from either of these two methods.
4. When the unit senses the tach signal, the parking lights will begin to flash.
6. Allow the vehicle to settle to a normal idle speed.
7. Release the brake pedal. The parking lights will turn on for 2 seconds and 1 long chip will indicate that the tach signal has been stored, and that the unit has exited tach learn mode.

**NOTE:** If the unit fails to learn tach rate due to an improper tach connection or a poor tach source, the parking lights will not flash. To correct this situation, locate and connect the PURPLE/WHITE wire to the proper tach signal, and then repeat the tach learn routine.

## Smart Tachless Mode

Smart Tachless Mode is available only if a tach signal has never been learned to the system and when activated will automatically change the Tach Mode feature in option programming to Tachless without the need to enter the feature programming mode.

1. Activate the remote start. The parking lights should begin flashing 7 times indicating no tach signal has been learned.
2. Within the 7 flash time period, press and hold the  button.
3. The system will chirp 1 time indicating the system is now in tachless mode.

## Chirp Delete - User Accessible

System ARM/DISARM chirps can be toggled ON or OFF without entering the programming feature banks.

1. Turn the ignition ON then OFF.
2. Press and release the valet/programming button 3 times. The system will respond with 1 chirp for ON or 2 chirps for OFF.

## User Selectable LED

This feature will control whether the LED is ON or OFF when the system is Armed/Locked. This will be selectable in feature programming OR on-the-fly without entering the programming feature banks.

1. Turn the ignition ON, OFF, ON, OFF.
2. Press and release the valet/programming button 3 times. The system will respond with 1 chirp for ON or 2 chirps for OFF.



## Dome Light Delay / Theater Dimming

The system can be programmed to delay arming after the lock button is pressed (60 second max) for vehicles with a dome light delay or theater dimming feature. Once programmed the system will 'learn' the timing of the dome light delay and add 2 seconds before arming.

1. Close all doors with ignition off.
2. Using the transmitter press LOCK, UNLOCK, LOCK, UNLOCK, LOCK, UNLOCK, LOCK. The LED will light solid to indicate the system has entered DOME DELAY LEARN MODE.
3. Immediately OPEN then CLOSE the door WITHOUT disarming the system. The system will then monitor the door trigger wire. Once the dome light turns off, the system will then add 2 seconds and then exit the learning mode.
4. The LED will begin to flash indicating the system has exited the learning mode and is now armed.

**Defaulting the Dome Light Delay:** Turn the ignition ON then OFF 3 times then press and hold the valet button for 5 seconds, the system will chirp 1 time indicating the learned delay time has been cleared.

## Feature Descriptions

### Feature Bank 2 - Security

#### 1 - **Silent Choice:** Controls the normal arm/disarm chirps of the security system.

**ON** - Silent arming/disarming upon first press of lock/unlock, pressing lock/unlock a second time will activate the arm/disarm chirps respectively. The system will only sound the arm/disarm chirps upon a second press of the lock/unlock buttons.

**OFF** - normal arm/disarm chirps upon the first press of lock/unlock.

#### 2 - **Door Locks:** Determines manual or automatic locking of the vehicle's doors.

**Active** - Requires use of the transmitter to lock the vehicle's doors.

**Passive** - Automatically locks the vehicle's doors 1 minute after the last door is closed.

**Note: For Passive Locks, feature #3, System Arming, must also be set to passive.**

#### 3 - **System Arming:** Determines manual or automatic locking of the vehicle's doors.

**Active** - Requires use of the transmitter to arm the security system.

**Passive** - Automatically arms the security system 1 minute after the last door is closed.

#### 4 - **System Notifications:** This feature selects which output(s) will sound the system's arm/disarm chirps. This feature does not effect the triggered state of the security system and during a triggered cycle, both the siren and horn outputs will activate respectively.

**Siren & Horn** - Siren and horn both sound when arming/disarming the system.

**Siren Only** - Only the siren will sound when arming/disarming the system.

**Horn Only** - Only the horn will sound when arming/disarming the system.

#### 5 - **Alarm Duration:** This feature controls the length of time the system will sound when triggered.

**30 Seconds** - When triggered, the system will sound the siren/horn for 30 seconds then stop. The unit will remain armed and may be triggered again.

**60 Seconds** - When triggered, the system will sound the siren/horn for 60 seconds then stop. The unit will remain armed and may be triggered again.

**6 - Security:** Controls security functionality - ON / OFF.

**ON** - Full security functionality.

**OFF** - The security system does not trigger. Panic, Remote Start and all other convenience features operate as normal.

**ON w/OEM Remote Start Compatibility** - This will prevent a vehicle's factory remote start from triggering the security system when activated. The system will use the ignition input to shunt shock and door inputs until 5 seconds after they clear. If the alarm is triggered prior to ignition on, then ignition will not shunt/cancel the alarm's triggered state. Also, note that the ignition input will no longer serve as a trigger if this option is selected on.

**7 - Anti-Hijack Mode:** Controls carjack mode - ON / OFF.

**OFF** - Standard security system operation.

**ON** - Enables Carjack mode functionality as described in the owners manual.

**8 - Ground While Armed / Orange ( - ) Output:** Controls the output of the orange wire. This wire will either supply a ( - ) output when armed OR disarmed.

**9 - DBI Port Protocol / Telematic Protocol:** Determines the protocol type in which the DBI & Telematic ports use to interface with external modules.

**DBI / Voxx Telematic** - DBI port uses DBI Protocol, telematic port uses Voxx Telematic Protocol.

**ADS / Voxx Telematic** - DBI port uses ADS Protocol, telematic port uses Voxx Telematic Protocol.

**DBI / ADS Telematic** - DBI port uses DBI Protocol, telematic port uses ADS Telematic Protocol.

**ADS / ADS Telematic** - DBI port uses ADS Protocol, telematic port uses ADS Telematic Protocol.

**10 - Arm/Disarm Chirps:** Determines the number of chirps and parking light flashes when the system is armed/disarmed.

**Standard** - 2 chirps/light flashes with arm, 1 chirp/light flash with disarm.

**Inverted** - 1 chirp/light flash with arm, 2 chirps/light flashes with disarm.

**11 - LED Indicator:** Control of the status LED when the system is armed / locked.

**ON** - LED will flash when system is armed / locked

**OFF** - LED will not flash when system is armed / locked. Only applies to normal operation (armed/locked) and does not affect programming, valet mode, diagnostics, passive lock countdown or PTN.

**12 - Auto Re-Lock:** When Auto Re-lock is selected, the system will re-lock the vehicle after 3 minutes if the system was disarmed and a door was NOT opened within that set amount of time. A door opening within this time cancels Auto Re-Lock.

Note: This feature is separate from Passive/Active Arming

**OFF** - Standard operation.

**Lock Only** - The unit will re-lock the vehicle after 3 minutes if the system was disarmed and a door was NOT opened within that time.

**Arm & Lock (security units only)** - The system will arm and also re-lock the vehicle after 3 minutes if the system was disarmed and a door was NOT opened within that time.

**13 - Extended Parking Lights:** When selected, this feature will keep the parking lights on for an additional 30 seconds after the standard flashes when pressing lock or unlock.

**OFF** - Normal parking light function.

**After Unlock** - Parking lights will stay on for 30 seconds after normal unlock flashes.

**After Lock** - Parking lights will stay on for 30 seconds after normal lock flashes.

**After Lock & Unlock** - Parking lights will stay on for 30 seconds after normal lock and unlock flashes.

**14 - Parking Light Relay / Trunk ( - ) Output:** This feature gives the installer the ability to swap the functions of the Parking Light Relay & Trunk Output.

**Standard** - No change to outputs.

**Inverted** - When inverted, the Trunk Red / White ( - ) Output will function as the Parking Light Output and the Parking Light White & White/Red will function as the Trunk Output.

**15 - Parking Light Relay / Trunk ( - ) Output:** Controls the angle of tilt needed to trigger the alarm. Note that the zero point for the tilt sensor is calibrated each time the system arms. The sensor will also reset the zero point after the alarm cycle when triggered by tilt.

**3 Degrees of Tilt** – The alarm will trigger when the vehicle is tilted 3 degrees.

**1 Degree of Tilt** – The alarm will trigger when the vehicle is tilted 1 degree.

**OFF** – The tilt sensor is inactive and will not trigger the system.

## Feature Bank 3 - Output Control

**1 - Lock / Unlock Timing:** Controls the timing of the BLUE and GREEN lock output wires.

**1 Sec.** - Single 1 second lock pulse, single 1 second unlock pulse.

**3.5 Sec.** - Single 3.5 second lock pulse, single 3.5 second unlock pulse.

**1 Sec. Lock, 2x Unlock** - Single 1 second lock pulse, double 1 second unlock pulse.

**30 Sec. Lock, 2x Unlock** - Single 30 second lock pulse, double 1 second unlock pulse.

**2x Lock, 1 Sec. Unlock** - Double 1 second lock pulse, single 1 second unlock pulse.

**0.5 Sec. Pulse** - Single 0.5 second lock pulse, single 0.5 second unlock pulse.

**2 - Factory Disarm 2, Blue/Green Output:** Controls the timing of the Blue/Green Factory Disarm 2 wire.

**Factory Disarm** - Single 1 second pulse with unlock and remote start activation.

**2nd Unlock** - Same output timing as unlock with 2nd press of unlock only.

**Factory Disarm 2x 500mS** - Double 500mS second pulse with unlock and remote start activation.

**Factory Disarm 350mS** - Single 350mS second pulse with unlock and remote start activation.

**Factory Disarm 500mS** - Single 500mS second pulse with unlock and remote start activation.

**Factory Disarm w/ Unlock Timing** - Uses the timing option set for Unlock in Bank 3, Feature 1.

**3 - Ignition Locks:** Control of door locks when the ignition is cycled ON or OFF.

**OFF** - Door locks not activated by ignition.

**Lock / Unlock** - Doors lock when ignition is turned on and unlock when ignition is turned off.

**Lock Only** - Doors lock when ignition is turned on.

**Unlock Only** - Doors unlock when ignition is turned off.

**4 - Trunk Output Timing:** Controls the output timing/type of the RED/WHITE output.

**1 Sec.** - 1 second pulse output.

**10 Sec.** - Continuous output for 10 seconds.

**20 Sec.** - Continuous output for 20 seconds.

**Latched until IGN ON** - Continuous output until the vehicle's ignition is turned ON.

**Latched ON until Button Press** - Continuous output until the activation button is pressed again.

**5 - Horn Output Timing:** Control the minimum horn pulse time in milliseconds, some vehicle will require a longer pulse to activate the factory horn.

**16mS    10mS    30mS    40mS    50mS**

**6 - Real Panic:** Controls the horn output when the system is triggered.

**ON** - Randomized horn honks when panic is triggered.

**OFF** - Standard pattern horn honks when panic is triggered.

**7 - AUX 1:** Controls the VIOLET/BLACK AUX 1 output activation type and timing.

**1 Sec. Pulse** - Single 1 second pulse.

**Latched** - Output stays active until button is pressed again.

**Latched until IGN ON** - Output stays active until the ignition is turned on.

**Dome Light Output** - Output used for illuminated entry and is not controlled by the AUX 1 function of the transmitter.

**Defrost Output Single Pulse** - Single 1 second pulse after start

**Defrost Output Latched 5 Minutes** - 5 minute continuous output after remote start.

**8 - AUX 2:** Controls the WHITE/BLACK AUX 2 output activation type and timing.

**1 Sec.** - Single 1 second pulse.

**Latched** - Output stays active until button is pressed again.

**Latched until IGN ON** - Output stays active until the ignition is turned on.

**10 Sec. w/ Arm** - Output stays active for 10 seconds with press of lock button.

**10 Sec. w/ Disarm** - Output stays active for 10 seconds with press of unlock button.

**L.E.D. Output** - Output will mimic the flash patterns of the systems status LED.

- 9 - AUX 3:** Controls the GRAY/BLACK AUX 3 output activation type and timing.
- 1 Sec.** - Single 1 second pulse.
  - Latched** - Output stays active until button is pressed again.
  - Latched until IGN ON** - Output stays active until the ignition is turned on.
  - 10 Sec. w/ Arm** - Output stays active for 10 seconds with press of lock button.
  - 10 Sec. w/ Disarm** - Output stays active for 10 seconds with press of unlock button.
  - L.E.D. Output** - Output will mimic the flash patterns of the systems status LED.
- 10 - AUX 4:** Controls the ORANGE/BLACK AUX 4 output activation type and timing.
- 1 Sec.** - Single 1 second pulse.
  - Latched** - Output stays active until button is pressed again.
  - Latched until IGN ON** - Output stays active until the ignition is turned on.
  - 10 Sec. w/ Arm** - Output stays active for 10 seconds with press of lock button.
  - 10 Sec. w/ Disarm** - Output stays active for 10 seconds with press of unlock button.
  - L.E.D. Output** - Output will mimic the flash patterns of the systems status LED.
- 11 - AUX 5:** Controls the PINK/BLACK AUX 5 output activation type and timing.
- 1 Sec.** - Single 1 second pulse.
  - Latched** - Output stays active until button is pressed again.
  - Latched until IGN ON** - Output stays active until the ignition is turned on.
  - 10 Sec. w/ Arm** - Output stays active for 10 seconds with press of lock button.
  - 10 Sec. w/ Disarm** - Output stays active for 10 seconds with press of unlock button.
  - L.E.D. Output** - Output will mimic the flash patterns of the systems status LED.

## Feature Bank 4 - Remote Start Control

**1 - RF Start Confirmation Chirp:** Turns remote start activation confirmation chirps ON or OFF. When ON the system will chirp 1 time when the remote start is activated.

**2 - Run Time:** Controls the time in minutes that the vehicle will stay running under control of the remote start until the system times out. The system may also be shut down at any time by use of the transmitter or system shutdowns.

**15 Min   5 Min   10 Min   20 Min   45 Min   60 Min**

**3 - Running Lights:** Controls the WHITE parking light output wire during remote start.

**Steady** - Parking lights constant during the remote start cycle.

**Flashing** - Parking lights flash at a slow pace during the remote start cycle.

**4 - Tach Mode:** Determines how the system monitors the engine running and if remote start was successful.

**Tach** - Purple/White tach input wire hard-wired directly to the vehicle's tach wire to monitor the engine's tach rate.

**Tachless** - Determined by the voltage difference before, and then after, remote start as set in Bank 4, feature 5.

**Hybrid** - No Sensing, the system will assume the vehicle has started. The system does NOT monitor voltage or tach rate in this mode to determine if the vehicle is running.

**DBI Port** - Monitors the vehicle's tach rate through an interface module connected to the DBI port.

**5 - Voltage Level:** The voltage variance for remote start when set to tachless. (see tach mode)

**HIGH** - The variance in battery voltage from before the remote start is activated to after the engine is running must be greater than 0.5 volts.

**LOW** - The variance in battery voltage from before the remote start is activated to after the engine is running may be less than 0.5 volts.

**6 - Crank Time:** Preset output times for the PURPLE starter wire.

**1 Second    0.8 Seconds    1.5 Seconds    2 Seconds    4 Seconds**

**7 - Crank Output:** The length of time in which the remote start will crank the vehicle's starter.

**Crank Average** - Determines crank time by averaging the last 8 times the vehicle was started with the key.

**Preset Time** - Preset starter output time. (see crank time)



**8 - Diesel Delay:** Selects engine type and delay time for the starter output wire during remote start activation.

**Gas** - Gasoline engine, no delay for the starter output wire.

**10 Sec. Delay** - Diesel engine, delays the starter output wire for 10 seconds after the ignition has been powered up by the remote start.

**15 Sec. Delay** - Diesel engine, delays the starter output wire for 15 seconds after the ignition has been powered up by the remote start.

**20 Sec. Delay** - Diesel engine, delays the starter output wire for 20 seconds after the ignition has been powered up by the remote start.

**45 Sec. Delay** - Diesel engine, delays the starter output wire for 45 seconds after the ignition has been powered up by the remote start.

**9 - Remote Start Activation:** Switches the remote start activation between a single or double press from the transmitter.

**2x Start** - Press and release the Start Button 2 times to activate remote start. Press and hold the start button for 3 seconds to shutdown.

**1x Start** - Press and release the Start Button 1 time to activate remote start. Press and hold the start button for 3 seconds to shutdown.

**10 - Ignition 2 Output Pink/White:** Programmable high current output.

**Ignition 2** - Output becomes active with the same timing as the ignition output and does not drop out during crank.

**Accessory** - Output becomes active with the same timing as the accessory output, drops out during crank.

**Start / Crank** - Output becomes active with the same timing as the starter output wire, during crank only.

**11 - Auto Start Interval:** This setting controls the timing for the 2 / 3 Hour Start Up Timer. Once activated, the system will remote start the vehicle every 2 or 3 hours over a maximum period of 48 hours unless cancelled.

**3 Hour** - When activated, the remote start will activate every 3 hours and run for the programmed time and shutdown.

**2 Hour** - When activated, the remote start will activate every 2 hours and run for the programmed time and shutdown.

**12 - Turbo Timer:** When activated, the vehicle will run for the programmed time.

**OFF      1 Minute      3 Minutes      5 Minutes**

**13 - Transmission Mode:** Select the type of remote start activation based on the vehicle's transmission type.

**Automatic** - For use with automatic transmission vehicles. Standard remote start operation.

**Manual** - For use with manual transmission vehicles. Remote start ready mode must be set upon exit of vehicle to enable remote start.

**14 - Temperature Start:** Sets the threshold temperature for temperature start mode. When temperature start is activated, the remote start function will activate when the ambient temperature drops below the selected temperature.

**15 - Accessory Output, Orange:** Programmable high current output.

**Accessory** - Output becomes active with the same timing as the accessory output, drops out during crank.

**Ignition** - Output becomes active with the same timing as the ignition output and does not drop out during crank.

**Start / Crank** - Output becomes active with the same timing as the starter output wire, during crank only.

**16 - Pulse Outputs w/ Unlock:** When the Unlock button is pressed on the remote transmitter the system will also simultaneously pulse additional outputs. Ignition, Accessory & Ground While Running outputs for 1 second. The 3rd setting also activates the pulse after shutdown output to turn off the RAP on certain vehicles.

**OFF** - When Unlock is pressed no additional outputs are activated.

**IGN, ACCY, GWR** - When the Unlock button is pressed the system will also simultaneously pulse the Ignition, Accessory & Ground while Running outputs for 1 second.

**IGN, ACCY, GWR, then Pulse After Shutdown** - When the Unlock button is pressed the system will also simultaneously pulse the Ignition, Accessory & Ground while Running outputs for 1 second then waits 2 seconds then pulses the green/white pulse after shutdown wire for 1 second.

**17 - RS Door Lock Control:** Controls the systems door lock outputs during the remote start sequence.

**OFF** - The system will not lock or unlock the vehicle.

**Unlock before Start, Lock After Start** - Unlock Pulse before remote start sequence begins, Lock pulse after remote start sequence is complete and engine is running.

**Unlock Before Start** - Unlock Pulse before remote start sequence begins.

**Lock After Start** - Lock pulse after remote start sequence is complete and engine is running.

**Lock After Shutdown** - Lock pulse after remote start shutdown sequence is complete.

## Feature Bank 5 - Alternate Output Control

**1 - Factory Disarm, Lt Green/Black Output:** Controls the LT GREEN/BLACK output activation type and timing.

**Pulse before Start / During Unlock** - 1 second pulse when remote start is activated. Also a 1 second pulse when unlock is pressed.

**Ground While Running** - Continuous output for the entire remote start sequence until after the vehicle shuts down.

**Ignition** - Output becomes active with the same timing as the ignition output and does not drop out during crank.

**Accessory** - Output becomes active with the same timing as the accessory output, drops out during crank.

**Pulse During Crank** - Output becomes active with the same timing as the starter output wire, during crank only.

**Pulse Before Start / During Unlock, Uses Unlock Timing** - Uses the same pulse time as door unlock set in Bank 3 / Feature 1 for pulsing when remote start is activated and when unlock is pressed.

**2 - Factory Arm, Lt Blue Output:** Controls the LT BLUE output activation type and timing.

**Pulse After Start / During Lock** - 1 second pulse after the remote start sequence and has confirmed the vehicle is running. Also a 1 second pulse when lock is pressed.

**Ground While Running** - Continuous output for the entire remote start sequence until after the vehicle shuts down.

**Ignition** - Output becomes active with the same timing as the ignition output and does not drop out during crank.

**Accessory** - Output becomes active with the same timing as the accessory output, drops out during crank.

**Pulse During Crank** - Output becomes active with the same timing as the starter output wire, during crank only.

**Pulse After Start / During Lock, Uses Lock Timing** - Uses the same pulse time as door lock set in Bank 3 / Feature 1 for pulsing after the remote start sequence and has confirmed the vehicle is running and when lock is pressed.

**3 - Pulse After Shutdown, Green/White Output:** Controls the GREEN/WHITE output activation type and timing.

**Pulse After Shutdown** - 2 second pulse after the remote start has shutdown.

**Ground While Running** - Continuous output for the entire remote start sequence until after the vehicle shuts down.

**Ignition** - Output becomes active with the same timing as the ignition output and does not drop out during crank.

**Accessory** - Output becomes active with the same timing as the accessory output, drops out during crank.

**Pulse During Crank** - Output becomes active with the same timing as the starter output wire, during crank only.

**Pulse after Shutdown 2 Sec. Delay** - Delays activating the Pulse After Shutdown output for 2 additional seconds.

**4 - Pulse During Crank, Black/Yellow Output:** Controls the BLACK/YELLOW output activation type and timing.

**Pulse During Crank** - Output becomes active with the same timing as the starter output wire, during crank only.

**Ground While Running** - Continuous output for the entire remote start sequence until after the vehicle shuts down.

**Ignition** - Output becomes active with the same timing as the ignition output and does not drop out during crank.

**Accessory** - Output becomes active with the same timing as the accessory output, drops out during crank.

**Pulse before Start / During Unlock** - 1 second pulse when remote start is activated. Also, a 1 second pulse when unlock is pressed.

**Pulse Before Start / During Unlock, Uses Unlock Timing** - Uses the same pulse time as door unlock set in Bank 3 / Feature 1 for pulsing when remote start is activated and when unlock is pressed.

## Feature Bank 6 -

### Shock Sensor Programming, Adjustment and Testing

1. Turn the ignition ON.
2. Press and hold the valet/override button.
3. Within 10 seconds the system will chirp (3) three times.
4. Use the valet/override button to advance through each option bank. For Shock Sensor Adjustment advance to Feature Bank 6, which is (8) eight chirps.
5. Turn the ignition OFF, exit the vehicle and close all doors.
6. Select Auto-Learning or Manual Adjustment:

#### Option (a) Auto-Learning

- a1. Press and hold the transmitter Start button until the system emits 2 long chirps to enter Shock Sensor Auto-Learning Mode.
- a2. Strike the vehicle to set the level intended for the system to trigger.
- a3. The system will store the setting, chirp 1 time and automatically advance to step 7, Manual Adjustment and Testing.

#### Option (b) Manual Adjustment

- b1. Press and hold the transmitter FIND button until the system emits 1 long chirp to advance to step 7, Manual Adjustment and Testing.
7. Manual Adjustment and Testing. Adjustment and testing can be performed at any time during this step. During testing 3 short chirp indicates warn-away, 1 long chirp indicates full trigger. Allow 3 seconds between each adjustment/test.
  - a. Full trigger – Press the transmitter LOCK button to increase sensitivity. Press the UNLOCK button to decrease sensitivity.
  - b. Warn-Away – Press the FIND Button to increase sensitivity. Press the START button to decrease sensitivity.
8. Programming will exit by turning the ignition ON or if there is no activity for 60 seconds. The system will flash the parking lights 3 times to confirm exit.

**Note:** Sensitivity ranges from 0 (OFF) – 27 (most sensitive), the default setting is 4. The system will chirp when sensitivity is raised or lowered with 2 chirps indicating the highest or lowest setting.

**Note:** During remote start, the system will ignore the sensor upon ignition until after remote start shutdown.

**Defaulting the Shock Sensor:** Enter Feature Bank 6, step 6 and press and hold the UNLOCK button for 3 seconds, the system will emit 1 long chirp to confirm reset and will return to step 6. Continue with step 6 or exit programming.

## Transmitter Button Functions

4-Button Transmitter	Lock	Unlock	Car Find / Panic	Start	Operation Method
Lock	X				Press and Release
Unlock		X			Press and Release
2 Step Unlock		X			Press and Release 2 times
Trunk		X			Push and Hold (3 Sec)
Car Finder			X		Press and Release
Panic			X		Push and Hold (3 Sec)
Remote Start				X	Press and Release (1 or 2 times depending on selectable option)
Remote Start Shutdown				X	Push and Hold (3 Sec)
Run Time Extension				X	Press and Release 4 times.
AUX 1	X	X			Push and Hold (3 Sec)
Shock Bypass	X		X		Press and Release Lock then Press Lock + Car Find
Hidden Alarm	X		X		Press and Release Car Find then Press Lock
Passive Arming Bypass		X	X		Press and Release
Turbo Timer		X		X	Press Unlock + Start
2 / 3 Hour Start				X	Ignition ON/OFF, Press and Hold Valet Button, Press Start 4 times
Daily Start Timer	X			X	Press Lock + Start
Temperature Start		X		X	Press Unlock + Start While Armed
<b>AUX 2, 3, 4, 5 - Access in AUX Mode</b>					
Enter AUX Mode			X	X	Press and Hold Find + Start Transmitter LED flashes 1 time
AUX 2	X				Push and Hold (3 Sec)
AUX 3		X			Push and Hold (3 Sec)
AUX 4			X		Push and Hold (3 Sec)
AUX 5				X	Push and Hold (3 Sec)

LCD 5-Button Transmitter	Lock	Unlock	Car Find / Panic	Start	Function	Operation Method
Lock	X					Press and Release
Unlock		X				Press and Release
2 Step Unlock		X				Press and Release 2 times
Trunk		X				Push and Hold (3 Sec)
Car Finder			X			Press and Release
Panic			X			Push and Hold (3 Sec)
Remote Start				X		Press and Release (1 or 2 times depending on selectable option)
Remote Start Shutdown				X		Push and Hold (3 Sec)
Run Time Extension				X		Press and Release 4 times.
AUX 1	X	X				Push and Hold (3 Sec)
Shock Bypass	X		X			Press and Release Lock then Press Lock + Car Find
Hidden Alarm	X		X			Press and Release Car Find then Press Lock
Passive Arming Bypass		X	X			Press and Release
Turbo Timer		X		X		Press Unlock + Start
2 / 3 Hour Start				X		Ignition ON/OFF, Press and Hold Valet Button, Press Start 4 times
Daily Start Timer	X			X		Press Lock + Start
Menu					X	Press and Hold
Temperature Start		X		X		Press Unlock + Start While Armed
<b>AUX 2, 3, 4, 5 - Access in AUX Mode</b>						
Enter AUX Mode					X	Press and Hold F for 2 seconds LCD displays AU
AUX 2	X					Push and Hold (3 Sec)
AUX 3		X				Push and Hold (3 Sec)
AUX 4			X			Push and Hold (3 Sec)
AUX 5				X		Push and Hold (3 Sec)



## Security Trigger Zones

If the security system has been triggered the **LED** will flash one of the patterns below indicating the zone.

<b>LED FLASHES</b>	<b>TRIGGER ZONE</b>
2 Flashes	Hood / Trunk Input
3 Flashes	Door Input
4 Flashes	Shock Sensor
5 Flashes	Ignition Input
6 Flashes	Tilt Sensor

## Remote Start Shutdown Diagnostics

If the remote start shuts down or fails to start, the **LED/parking lights** will flash one of the patterns below indicating the shutdown input.

To manually enter diagnostics and view the last shutdown, turn the ignition ON and press and release the  button, the **LED** will flash one of the patterns below.

<b>FLASHES</b>	<b>SHUTDOWN ZONE</b>
3 Flashes	Hood Input Brake Input Neutral Safety Input
4 Flashes	Remote Start Valet Mode
5 Flashes	Manual Transmission Mode not set (manual transmission models only)
7 Flashes	Tach not learned / Crank Average not learned

# System Layout

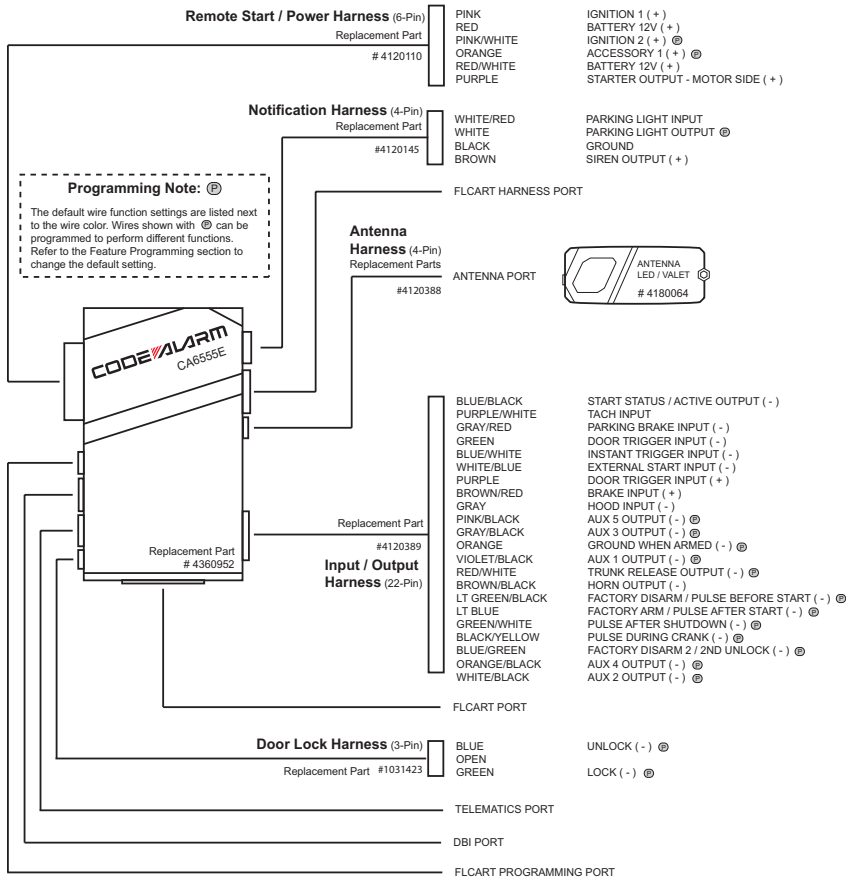

## Programming Note: Ⓞ

The default wire function settings are listed next to the wire color. Wires shown with Ⓞ can be programmed to perform different functions. Refer to the Feature Programming section to change the default setting.

## Installation Note:

The module should be securely attached to a stable surface using zip ties in order for the on-board shock and tilt sensor to function properly.

## STARTER INTERRUPT RELAY & HARNESS

Replacement Part #1024405



**ORANGE**  
**RED**  
**BLACK**  
**WHITE / BLACK**

**86 - ARMED OUTPUT (-)**  
**85 - IGNITION (+)**  
**87A - STARTER OUTPUT - MOTOR SIDE**  
**85 - STARTER INPUT - KEY SIDE**



Voxx Electronics Corporation.  
Customer Service 1-800-421-3209  
WWW.CODE-ALARM.COM

**FCC COMPLIANCE**

This device complies with Part 15 of the FCC rules and with RSS-210 of Industry Canada. Operation is subject to the following two conditions:

1. This device may not cause harmful interference, and
2. This device must accept any interference received, including any interference that may cause undesired operation.

**Warning!**

Changes or modifications not expressly approved by the party responsible for compliance could void the user's authority to operate the equipment.

PATENTED: [www.voxxintl.com/company/patents](http://www.voxxintl.com/company/patents)