

## CD PROGRAMMED PLAYBACK

A program of up to 32 tracks from all the available discs in the disc tray can be played in a preset order.

1. Press the PROGRAM button (in stop mode). First "P01" will display for about 2 seconds and then Disc Number (example 4d) will flash on display. "P01" means you are setting the first programmed track.

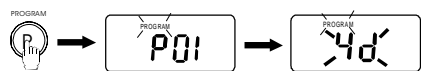

2. Press the DISC SKIP button to select the desired disc. (example 5d)



3. Press the SKIP buttons to select the desired track. (example the first track of Disc 5)

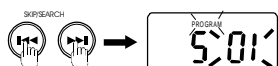

4. Press the PROGRAM button again to store this track in memory.

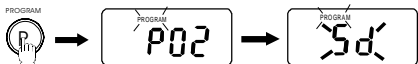

5. To add additional tracks, repeat steps 2 to 4.
6. To start playback, press the PLAY/PAUSE button.



### To check the program

After setting, press PLAY button, then press STOP button. In stop mode, press PROGRAM button to check the number of programs and the track order. This will not work when the disc is being played.

### To stop programmed play for a moment:

- Press the PLAY/PAUSE button and "||" will be displayed and the current track number will flash. Press this button again to resume playing.

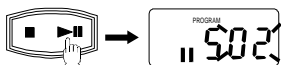

### To erase the whole program, do one of the following:

- Press STOP button twice to erase the program.
- Set the FUNCTION switch to other functions.
- Open the disc tray by pressing the OPEN/CLOSE button.



### NOTE:

- The same track can be selected more than once in the same program.
- With program on, the skip function is available only for the selected tracks.
- With program on, repeat play can be performed but disc skip function can not be done.

### To add additional tracks during program playback:

- Press STOP button first, the current playing disc No. will appear on the display. Press PROGRAM button, the first programmed No. and the track No. will appear on the display, repeat steps 2 to 4.

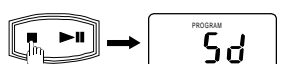

## USING THE CD STORAGE

- Open the CD Storage Door and insert the CD with the CD Box into the storage windows, maximum to insert six CD.

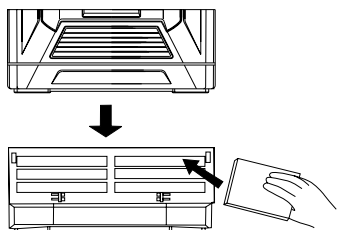

## REMOTE CONTROL (OPTIONAL)

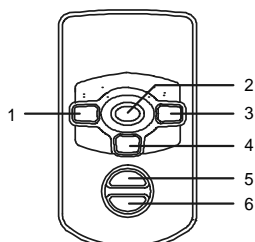

1. SKIP Button
2. REPEAT Button
3. +SKIP Button
4. DISC SKIP Button
5. PLAY/PAUSE Button
6. STOP Button

### USING THE REMOTE CONTROL CORRECTLY

- Point the Remote Control at the REMOTE SENSOR located on the unit.
- When there is a strong ambient light source, the performance of the infrared REMOTE SENSOR may be degraded, causing unreliable operation.
- The recommended effective distance for remote operation is about 4 meters (13 feet).

### TO CHANGE REMOTE CONTROL BATTERY

1. Open the battery door.
2. Insert one CR2025 (3V) size battery.

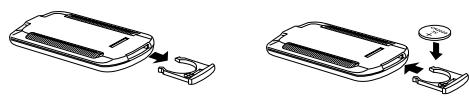

### ATTENTION

Take out the PVC sheet before operating the Remote Control.



### BATTERY REPLACEMENT

When battery becomes weak, the operating distance of the Remote Control is greatly reduced and you will need to replace the battery.

### NOTE:

If the Remote Control is not to be used for a long time, remove the battery to avoid damage caused by battery leakage corrosion.

## MAINTENANCE

### CLEANING CD

If the CD skips or will not play, the disc may need to be cleaned. Before playing, wipe the disc from the center out with a cleaning cloth. After playing, store the disc in its case.

### CLEANING THE UNIT

Do not use volatile chemicals on this unit. Clean by lightly wiping with a soft cloth.

### IMPORTANT NOTE:

If an abnormal display indication or an operating problem occurs, disconnect the AC power cord. Wait at least 5 seconds, then reconnect it. Before transporting the unit, take out all discs from the CD tray.

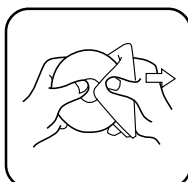

## SPECIFICATIONS

Power requirements	AC ~ 120V 60Hz (USA/CANADA) AC ~ 220V 50Hz (other countries) AC ~ 230-240V 50Hz (Europe) AC ~ 240V 50Hz (Australia) AC ~ 110-120V/220-240V 50/60Hz (other countries)
Power consumption	10 W

# 5 CD CHANGER HOME STEREO SYSTEM OPERATING INSTRUCTIONS

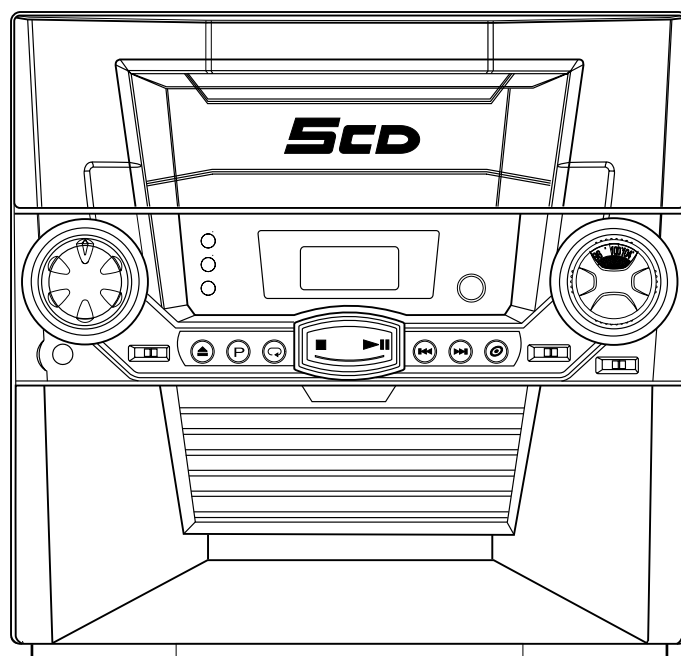

### WARNING

#### EXPLANATION OF GRAPHICAL SYMBOLS:

<b>WARNING</b> RISK OF ELECTRIC SHOCK. DO NOT OPEN.	The lightning flash with an arrowhead symbol, within the equilateral triangle, is intended to alert the user to the presence of uninsulated "dangerous voltage" within the product's enclosure that may be of sufficient magnitude to constitute an electric shock to persons.
<b>WARNING: TO REDUCE THE RISK OF ELECTRIC SHOCK, DO NOT REMOVE COVER (OR BACK). NO USER-SERVICEABLE PARTS INSIDE. REFER SERVICING TO QUALIFIED SERVICE PERSONNEL.</b>	The exclamation point within the equilateral triangle is intended to alert the user to the presence of important operating and maintenance (servicing) instructions in the literature accompanying the appliance.

**CAUTION**  
INVISIBLE LASER RADIATION  
WHEN OPEN AND INTERLOCK  
DEFEATED.  
AVOID EXPOSURE TO BEAM

**CLASS 1 LASER PRODUCT**

**WARNING: TO PREVENT FIRE OR SHOCK HAZARD, DO NOT EXPOSE THIS APPLIANCE TO RAIN OR MOISTURE.**

**CLASS 1 LASER PRODUCT**

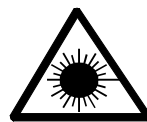

This product contains a low power laser device.

## TROUBLE SHOOTING GUIDE

The following checks will assist in the correction of most problems which you may encounter with your system. Before going through the check list below, first check the following points.

SYMPTOM	CAUSE (AND REMEDY)
<b>GENERAL</b>	
No sound.	• Turn VOLUME clockwise. • The headphones are connected. Disconnect them.
No sound from one channel or unbalanced left and right volume.	• Check the speaker connections of the inoperative channel.
Reversed left and right sound.	• Check the speaker cord connection and speaker location.
Lack of bass sound or apparently imprecise physical location of musical instruments.	• Check the speaker connection for proper phasing.
Severe hum or noise.	• The TV or VCR is too close to the stereo system. Separate the stereo system from the TV or VCR.
<b>RADIO RECEPTION</b>	
The FM STEREO indicator flashes.	• Wire the antenna.
Severe hum or noise.	• Wire the antenna.
<b>CD PLAYER OPERATION</b>	
Play does not start.	• The disc is not placed correctly. • Dirty disc. • The disc is inserted upside down. • The player is in the pause mode.
Distorted playback or sound loss during CD playback.	• Moisture condensation. • CD is dirty or scratched.

## IMPORTANT SAFETY INSTRUCTIONS

- 1) Read these instructions.
- 2) Keep these instructions.
- 3) Heed all warnings.
- 4) Follow all instructions.
- 5) Do not use this apparatus near water.
- 6) Clean only with dry cloth.
- 7) Do not block any ventilation openings. Install in accordance with the manufacturer's instructions.
- 8) Do not install near any heat sources such as radiators, heat registers, stoves, or other apparatus (including amplifiers) that produce heat.
- 9) Do not defeat the safety purpose of the polarized or grounding-type plug. A polarized plug has two blades with one wider than the other. A grounding type plug has two blades and a third grounding prong. The wide blade or the third prong are provided for your safety. If the provided plug does not fit into your outlet, consult an electrician for replacement of the obsolete outlet.
- 10) Protect the power cord from being walked on or pinch particularly at plugs, convenience receptacles, and the point where they exit from the apparatus.
- 11) Only use attachments/accessories specified by the manufacturer.
- 12) Unplug this apparatus during lightning storms or when unused for a long period of time.
- 13) Refer all servicing to qualified service personnel. Servicing is required when the apparatus has been damaged in any way, such as power-supply cord or plug is damaged, liquid has been exposed to rain or moisture, does not operate normally, or has been dropped.
- 14) This appliance shall not be exposed to dripping or splashing water and that no object filled with liquid such as vases shall be placed on the apparatus.

**Specifications and external appearance are subject to change without advance notice due to continuous product improvement.**

## PRECAUTIONS

Follow the advice below for safe and appropriate operations.

### ON PLACEMENT

- Do not use the unit in places which are extremely hot, cold, dusty, or humid.
- Place the unit on a flat and even surface.
- Do not restrict the air flow of the unit by placing it in a place with poor air flow, by covering it with a cloth, or by placing it on a carpet.

### ON AC VOLTAGE

- Before use, check that the rated voltage of your unit matches your local voltage.

### FCC INFORMATION (FOR USA ONLY)

This device complies with Part 15 of FCC Rules. Operations are subject to the following two conditions:

- This device may not cause harmful interference, and
- This device must accept any interference received, including interference that may cause undesirable operations.

### ON SAFETY

- When connecting or disconnecting the AC cord, grip the plug and not the cord itself. Pulling the cord may damage it and create a hazard.
- When you are not going to use the unit for a long period of time, disconnect the AC power cord.

### ON CONDENSATION

- When left in a heated room where it is warm and damp, water droplets or condensation may form inside the CD player.
- When there is condensation inside the unit, the unit may not function normally.
- Let it stand for 1 to 2 hours before turning the power on, or gradually heat the room up and dry the unit before use.

**Should any trouble occur, disconnect the AC power cord and refer servicing to qualified personnel.**

## SYSTEM CONNECTIONS

### SPEAKERS CONNECTING

- Connect the wires to the speaker terminals in correct position.
- Connect speakers other than the speakers supplied with the unit may damage the unit.

### AC POWER CONNECTING

- Before use, check that the rated voltage of your unit matches your local voltage. Make sure speakers are connected correctly before plugging the AC power cord into an AC outlet.

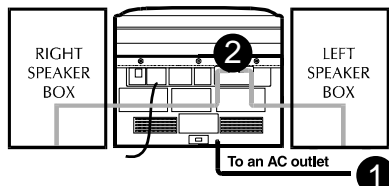

### CAUTION :

- Be sure the AC power cord is disconnected and all functions are off before making connections.

- TO PREVENT ELECTRIC SHOCK, MATCH WIDE BLADE OF PLUG TO WIDE SLOT, FULLY INSERT (FOR USA AND CANADA ONLY).**

### FM ANTENNA

- Do not connect to an outside antenna.

## PARTS IDENTIFICATION

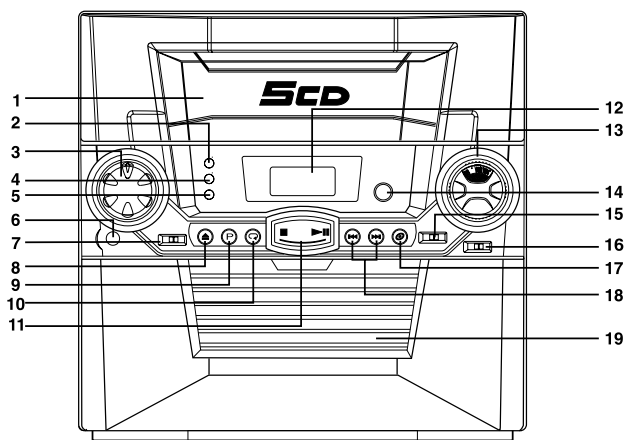

- |                                      |                                   |
|--------------------------------------|-----------------------------------|
| 1. CD door                           | 10. REPEAT button                 |
| 2. POWER/STANDBY indicator           | 11. CD PLAY/PAUSE/STOP button     |
| 3. VOLUME control                    | 12. CD display                    |
| 4. ON indicator                      | 13. TUNING control                |
| 5. FM STEREO indicator               | 14. Remote sensor (optional)      |
| 6. PHONES jack                       | 15. Mode selector (FM.ST/FM MONO) |
| 7. FUNCTION switch (ST.BY/ TUNER/CD) | 16. BAND selector (FM/AM)         |
| 8. CD OPEN/CLOSE button              | 17. DISC SKIP button              |
| 9. PROGRAM button                    | 18. CD SKIP/SEARCH buttons        |
|                                      | 19. CD STORAGE door               |

## GENERAL OPERATION

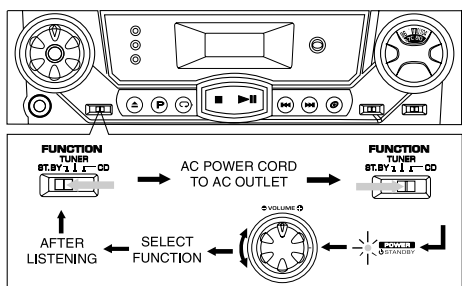

## COMPACT DISC (CD) DISPLAY

- REPEAT mode indicators
- DISC indicator
- Playback indicator
- Pause indicator
- Track indicator

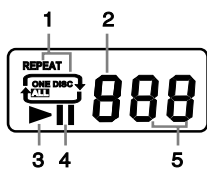

## SOUND ADJUSTMENT

### TO ADJUST THE VOLUME

Adjust the VOLUME control to obtain the desired volume level.

### FOR PERSONAL LISTENING

Connect headphones (Ø3.5mm stereo mini plug) to the PHONES jack. Adjust the VOLUME for the desired listening level. When headphones are connected, the speakers are automatically disconnected.

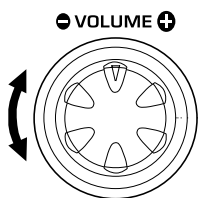

## RADIO OPERATION

- Set the FUNCTION switch to TUNER.
- Select the desired band.
- Tune into a station.
- Adjust the volume.

### FUNCTION TUNER

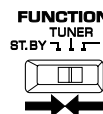

- Select the desired band.

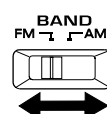

- Tune into a station.

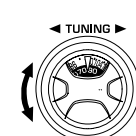

- Adjust the volume.

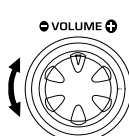

### FOR BETTER RECEPTION

Fully unwind the wire antenna. Then extend the wire antenna and place it in the position that sounds best.

### NOTE:

DO NOT CONNECT FM ANTENNA WIRE TO OUTSIDE ANTENNA.

Rotate the unit to get the best receiving position.

### FM

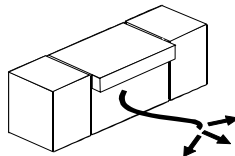

### AM / MW

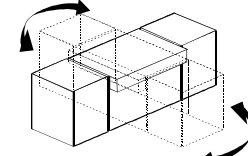

### TO RECEIVE THE FM BROADCAST IN STEREO

Set the Mode selector to FM.ST. When the FM STEREO broadcast is received, FM STEREO indicator lights up.

### IF THE FM BROADCAST SIGNAL IS WEAK

Set the Mode selector to FM MONO position to turn off the FM STEREO indicator and background noises become monaural.

### AFTER LISTENING

Set the FUNCTION switch to ST.BY (Standby).

## COMPACT DISC PLAYBACK

- Set the FUNCTION switch to CD.

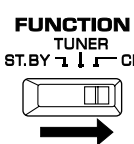

- Press the OPEN/CLOSE button to open the disc tray. Place the first disc onto the disc holder, with the label side up.

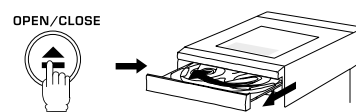

- Press the DISC SKIP button to revolve the tray clockwise. Place other disc(s) on the disc holder(s).

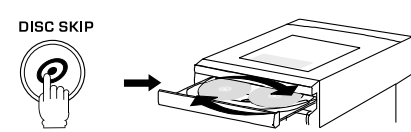

**WARNING:** Take out all discs from the disc tray before transportation.

- Press the OPEN/CLOSE button to close the disc tray. It takes a short while for your player to check the discs.

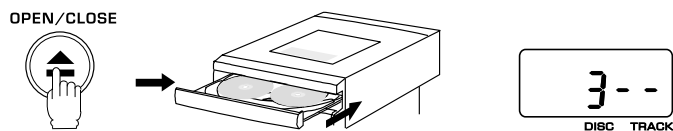

- Press the DISC SKIP button to select the desired disc. Press either one of the SKIP/SEARCH buttons to select the desired track.

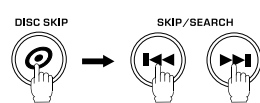

- Press the PLAY/PAUSE button to start playback.

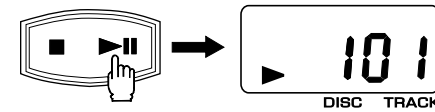

### To stop playing:

- For a moment only, press the PLAY / PAUSE button and "||" will be displayed. Press this button again to resume playing.
- Press the CD STOP button.

### NOTE:

- To locate a track of currently selected disc, press the SKIP/SEARCH button repeatedly.
- To locate a track of another disc, press the DISC SKIP button to get to desired disc first and then press the SKIP/SEARCH button repeatedly.
- To search a track, keep the SKIP/SEARCH button pressed and release it at desired point.

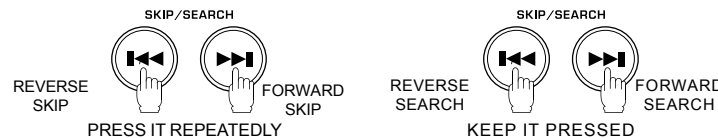

## CD REPEAT PLAYBACK

### REPEAT PLAYBACK - DURING PLAYBACK MODE

#### To repeat the current track

- Press REPEAT button until REPEAT ONE appears on the CD display and the currently playing track will be played repeatedly.
- Press the SKIP/SEARCH button with repeat function on, repeat can still skip through different tracks of the currently selected disc.

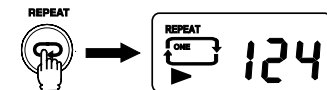

#### To repeat the whole disc

- By pressing the REPEAT button until REPEAT ONE DISC appears on the CD display, the current disc will be played repeatedly starting from the currently playing point.
- By pressing the SKIP/SEARCH button with REPEAT-ONE-DISC function on, one can still search through the whole disc, and the player will start playing from the selected point.



#### To repeat all discs

- Press REPEAT button until REPEAT ALL DISC appears on the CD display.
- By pressing on the SKIP/SEARCH button will make the player start playing from the newly selected point of the currently playing disc.
- By pressing on the DISC SKIP button will make the player start playing from the first track of the newly selected disc. The SKIP/SEARCH button can be used to choose a particular track on this selected disc, the player will then start playing from that point.

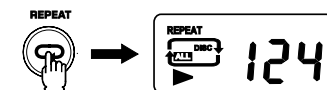

#### To cancel repeat play

- Press REPEAT button until the 'REPEAT' icon disappears from the CD display.

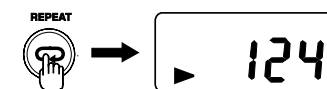

### ATTENTION - If the CD player does not operate properly

- Slide the FUNCTION switch from CD to ST.BY (standby).

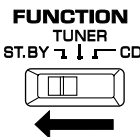

- Slide the FUNCTION switch from ST.BY to CD.

