

Full Display Mirror® Installation Instructions

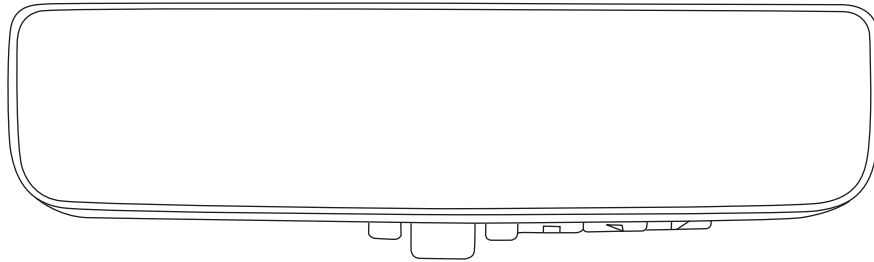

Congratulations and thank you for purchasing a Gentex brand Full Display Mirror (FDM®). This intelligent rear vision kit consists of a unique display-integrated mirror and custom-designed camera engineered specifically for automotive rear vision.

Tools required

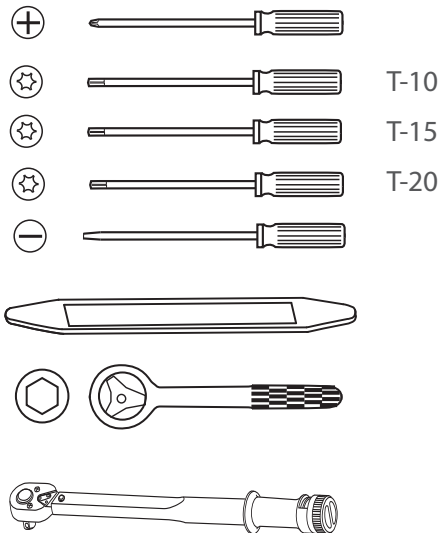

Full Display Mirror®, FDM®, HomeLink® and the HomeLink house icon are registered trademarks of Gentex Corporation.



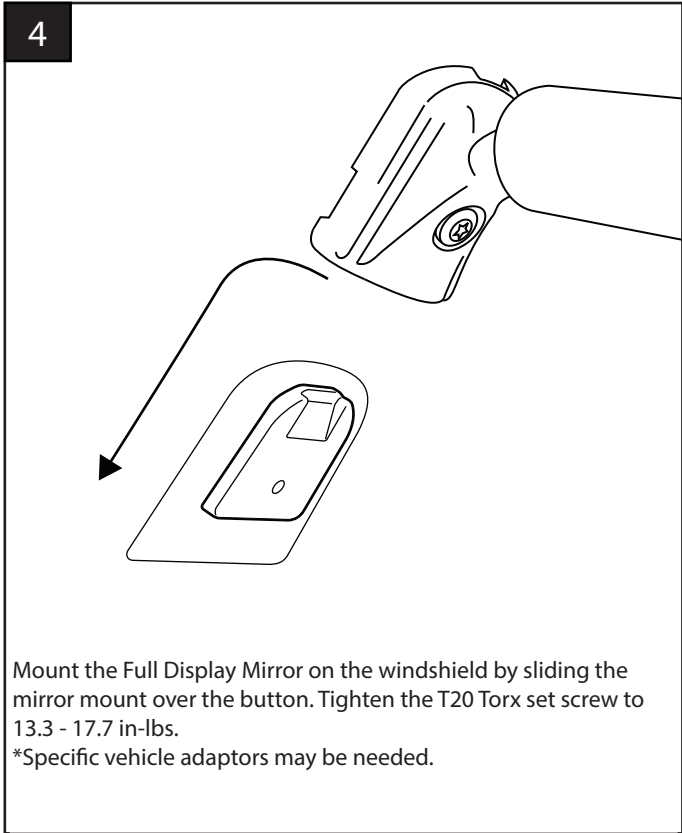
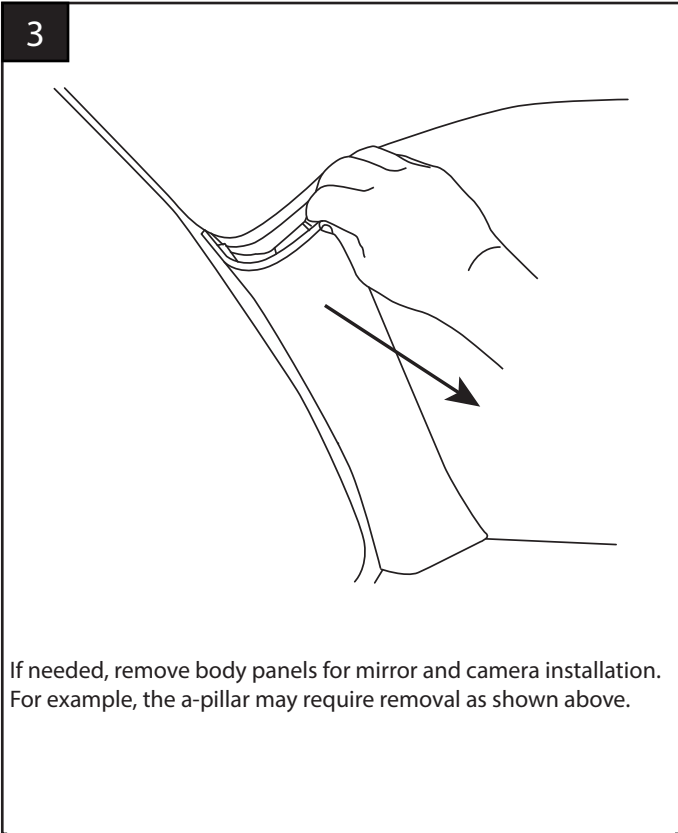
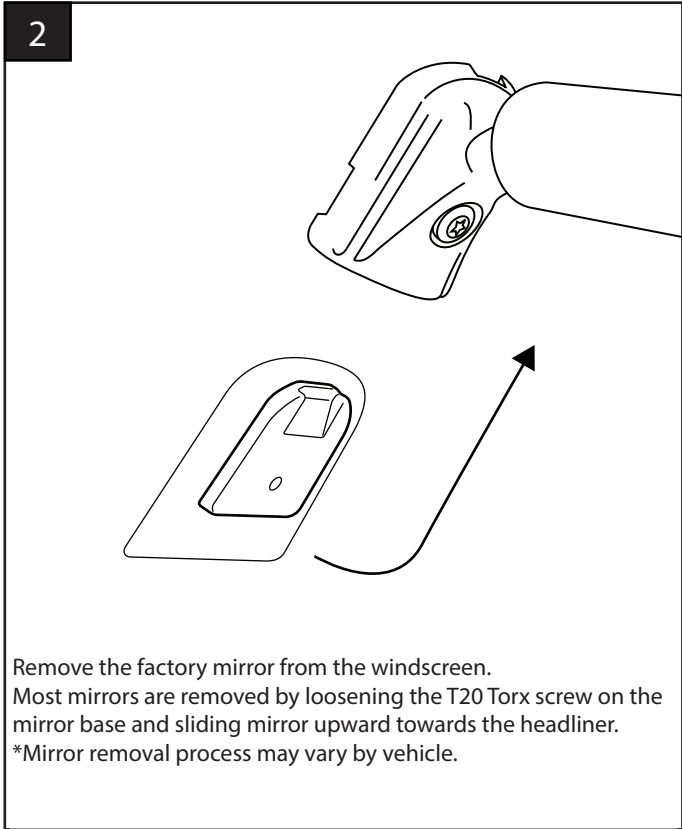
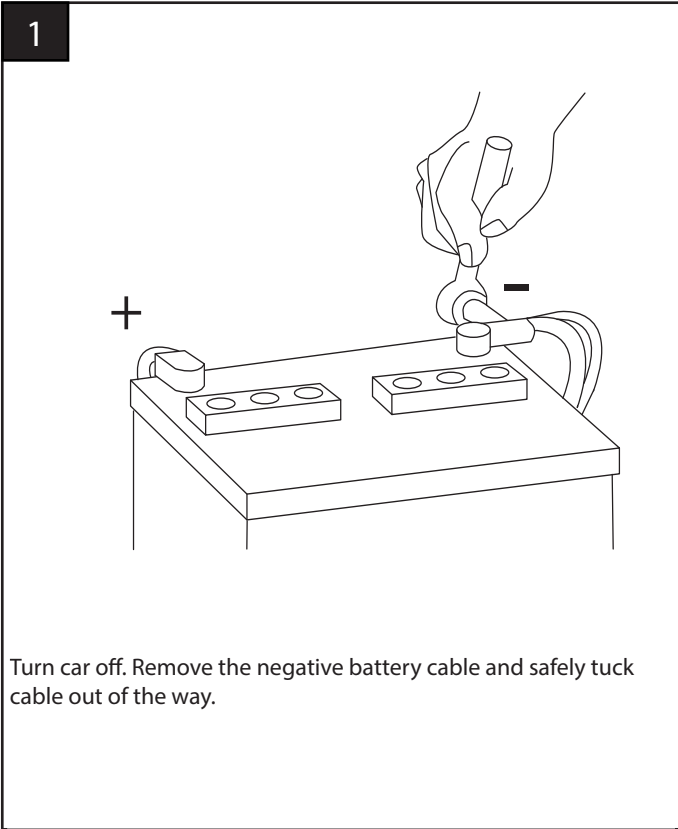

5

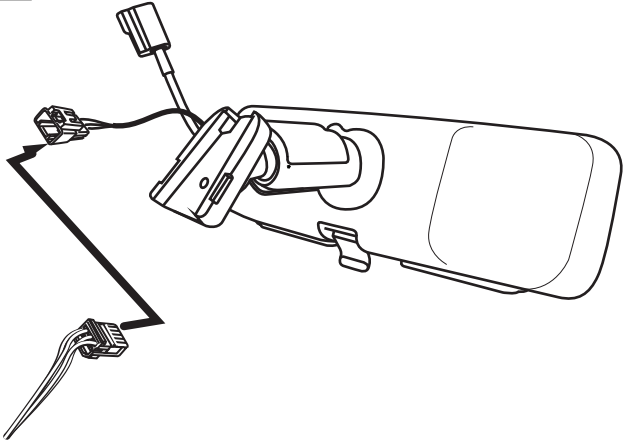

Plug mirror power harness into the connector on the mirror.

6

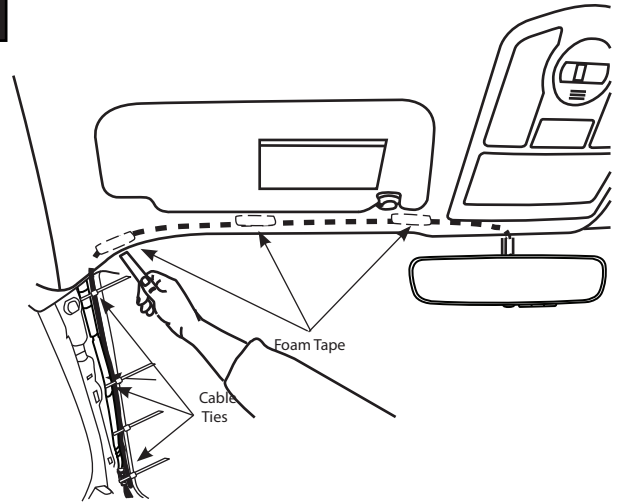

Route the mirror power harness to a location where 12v ignition and ground lines are present. Secure the harness along the route with foam tape and wire ties.

* Ignition and ground tap point are typically found in the A-pillar, Junction Block or Overhead compartment.

7

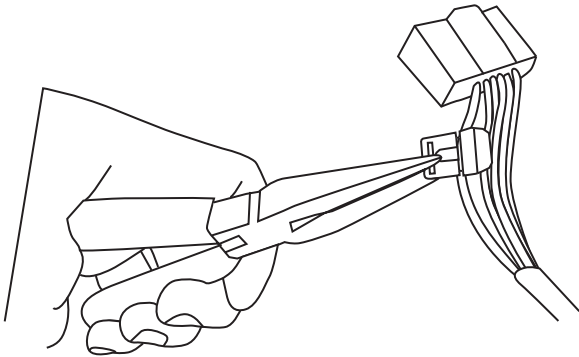

Find 12V switched ignition and attach t-tap using pliers. Repeat for ground supply. Ensure t-tap is snapped together.

8

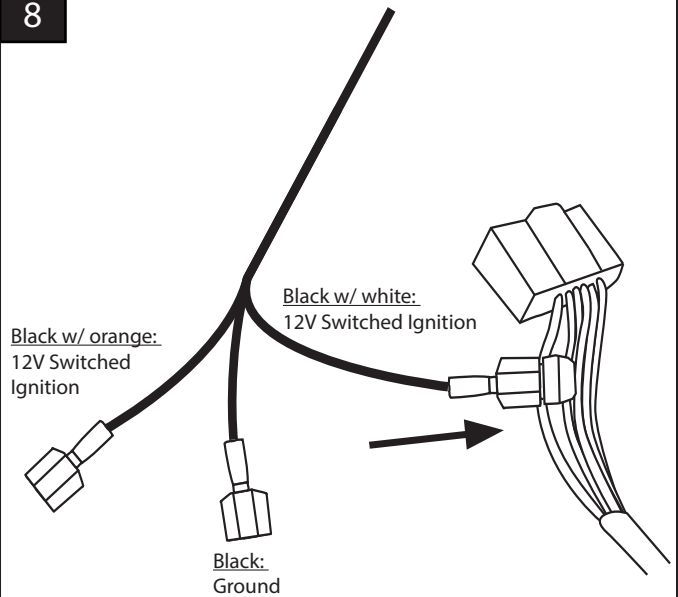

Plug the mirror harness into t-tap's as noted above. Ensure the spade is properly seated into t-tap.

9

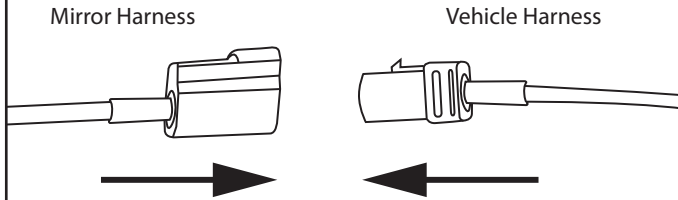

Plug the longest piece of coax harness into the female coax connector coming from the mirror. Wrap a piece of foam tape around connectors to prevent rattle.

10

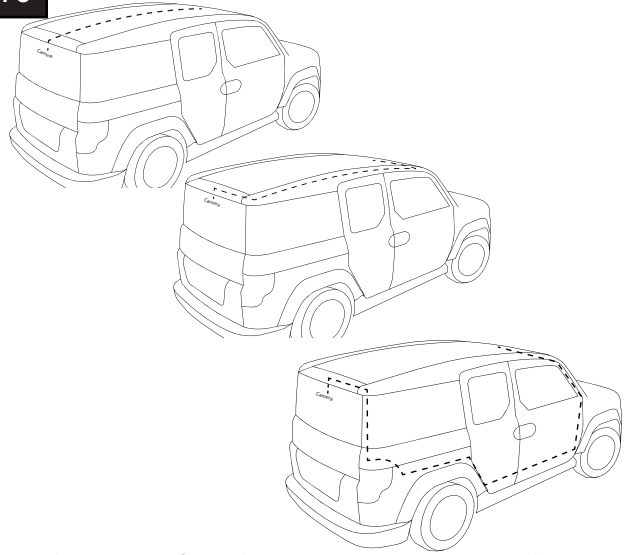

Route long piece of coax harness to camera mounting location. Secure coax harness along route with foam tape and/or cable ties. *If 90 degree connector cannot reach camera, another length of coax wire (purchased separately) can be used as an extension. The maximum recommended overall coax length is 30ft. It is also recommended to use cable ties every 150mm and within 30mm of a connector. Only use the 90 degree connector to plug into camera.

11

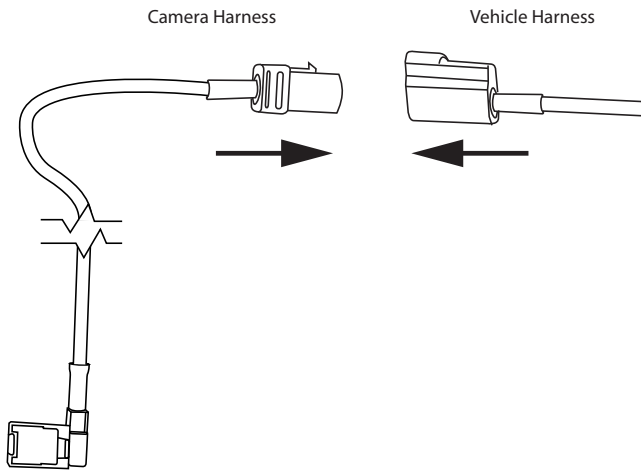

Plug shorter piece of coax harness into the long piece of coax harness. Wrap a piece of foam tape around connectors to prevent rattles. Ensure 90 degree connector can reach camera location. Secure harness along route with foam tape or cable ties.

12

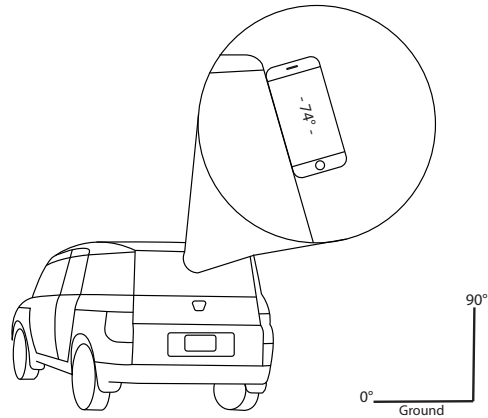

Choose camera mounting location inside the vehicle. Measure the angle at location chosen. Most smart phones have a built in angle finder.

Tips!
 Final mounting position of camera should be located as high as possible.
 Final mounting position of camera should be in between defrost lines and in wiper path, if possible to ensure unobstructed view.
 Final mounting position of camera should be in center of vehicle.
 Do not place camera on sliding or moving glass.
 Camera should only be mounted inside of vehicle.

13

17°-29°

30°-54°

55°-90°

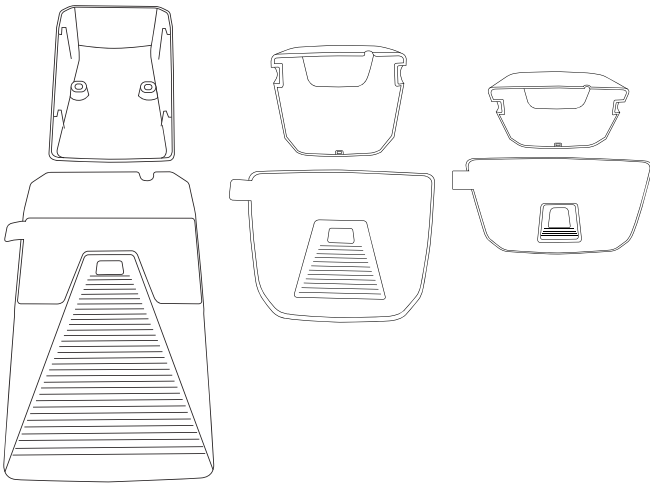

Choose appropriate window bracket for angle measured.

Examples:

17°-29° - Sports Cars/ Sedans

30°-54° - CUVs

55°-90° - SUVs/ Trucks

14

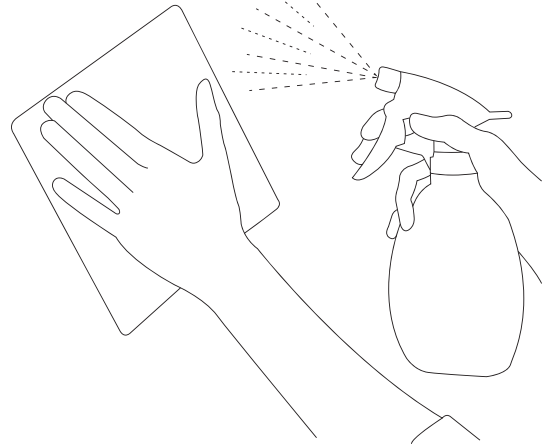

Clean both interior and exterior of glass of mounting location.
Ensure interior of glass is dry and debris free to ensure best foam adhesion during camera installation.

15

Bracket

Camera

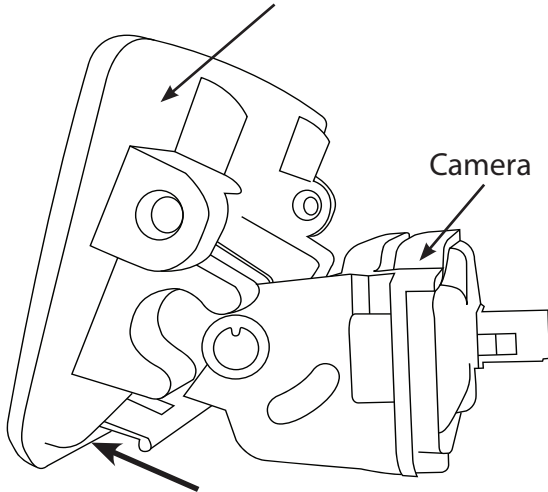

Install camera into window bracket (measured for vehicle).
Do NOT take off two way tape liner.

16

Set Screw

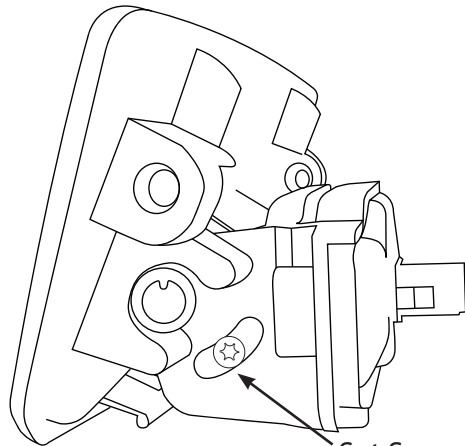

Screw in both T-10 camera set screws provided (one on each side).
Do NOT tighten.

17

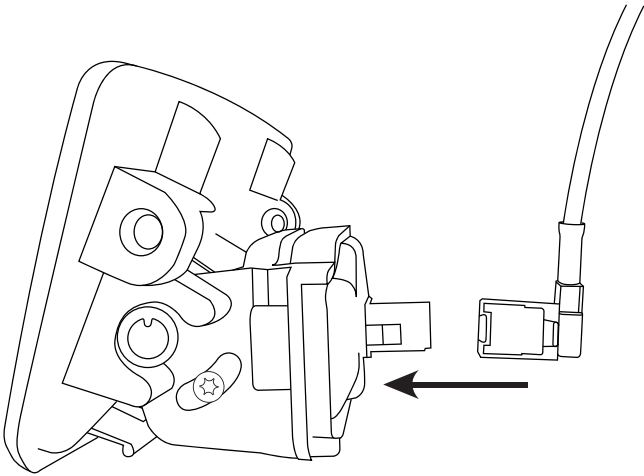

Plug the 90-degree coax cable into the camera.
Only the 90-degree cable can be used to plug into the camera!

18

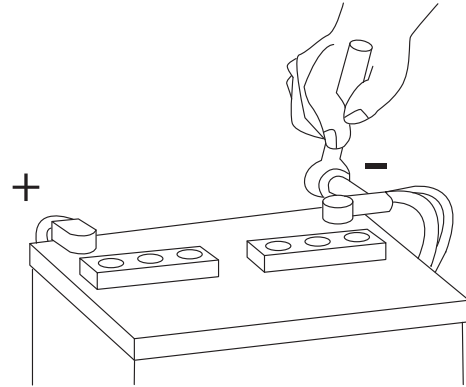

Reconnect the negative battery cable.

19

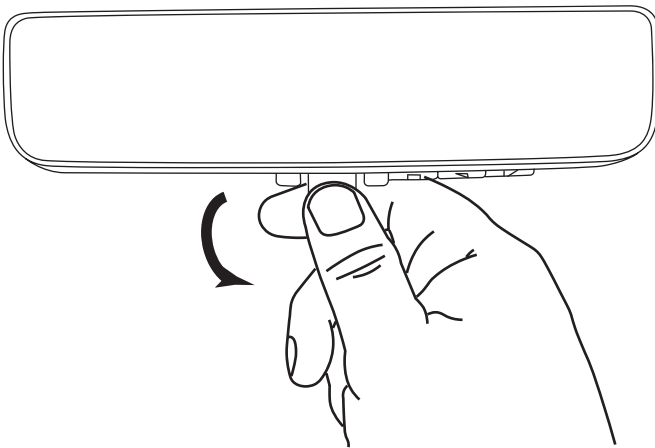

Toggle lever back towards rear of vehicle to place mirror in display mode.

20

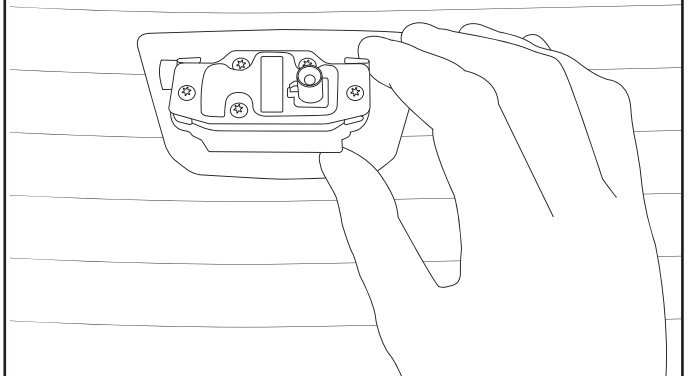

Do NOT take off two way tape liner. Hold camera bracket with camera to mounting location to test location chosen. Dry fit camera in location.

Tips!
Ensure camera cover does not interfere with vehicle interior.
Ensure coax cable can reach and can be tucked out of the way.

21

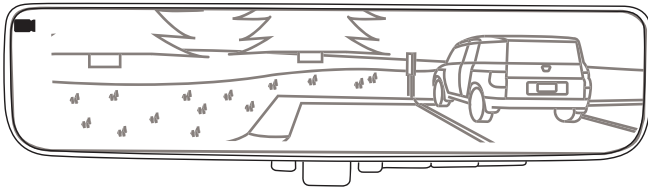

Do NOT take off two-way tape. With vehicle ignition on and mirror in display mode, aim the camera. Choose location that image looks best in mirror display.

Tips!

Ensure camera image is level.

Ensure camera can point at horizon.

22

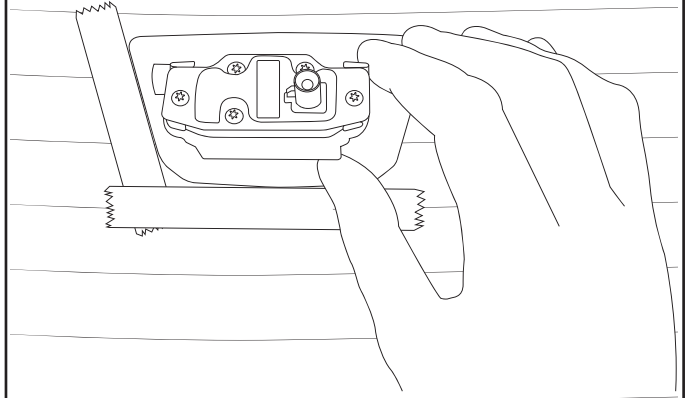

Using masking tape, mark the location at which you would like to mount the camera.

23

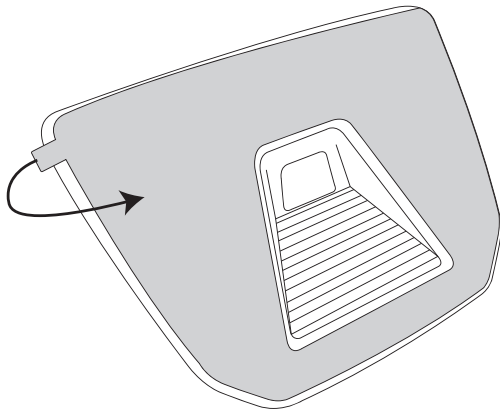

Double check the mounting location is correct. Remove two-way tape liner. Ensure debris or hand oils do not get on two-way tape.

24

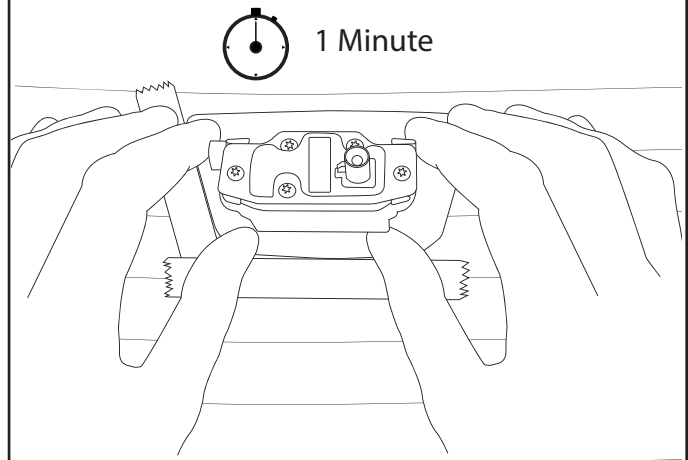

Caution!

Adhesive is difficult to remove. If done incorrectly, a new bracket and adhesive is recommended.

In mounting location, place window bracket onto rear glass. Press, hold, and apply even pressure across the entire surface. Press and hold for 1 minute. Install temp should be above 50 degrees fahrenheit.

25

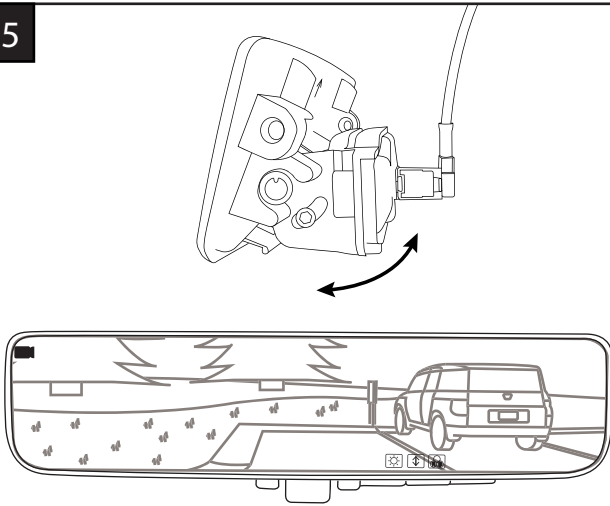

Adjust camera up or down on the window bracket so the image (in display mode) has the horizon in the upper third of the mirror. Tighten both set screws on camera mounting bracket. Do not over tighten.

26

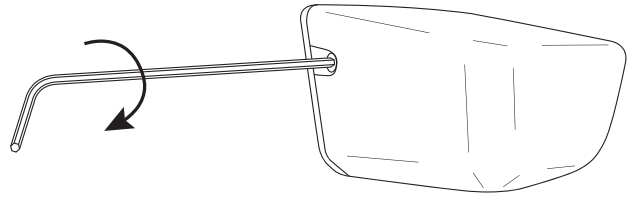

Install camera cover. Secure camera cover with the two T-15 screws provided. Do not over tighten.

27

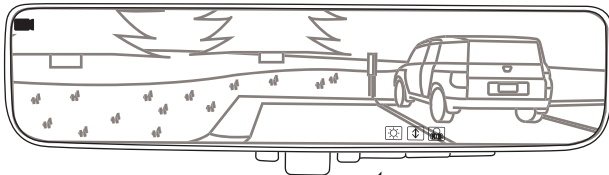

Mirror settings

Adjust camera image using mirror settings. Adjust the tilt up or down so the image is centered. The image may still appear rotated, however the product is equipped with an auto rotate feature. You will notice the screen shift periodically for the first 30-60 minutes of driving. After that time the image will be level. Please refer to quick reference guide for full menu instructions.

28

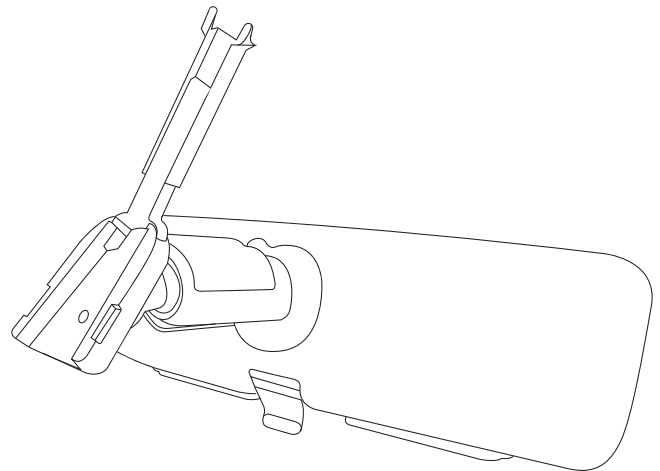

Install the wire cover over the two harnesses by seating the bottom of the cover into the mirror mount and then sliding the top of the cover up to the headliner.

29

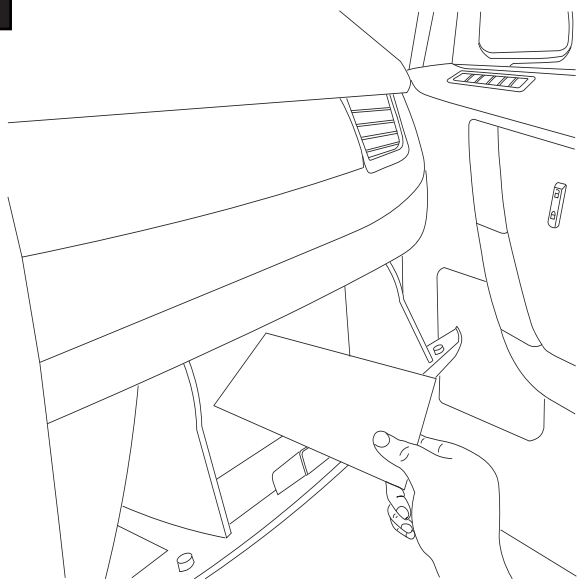

Place paper product (quick reference guide) in the glove box.

30

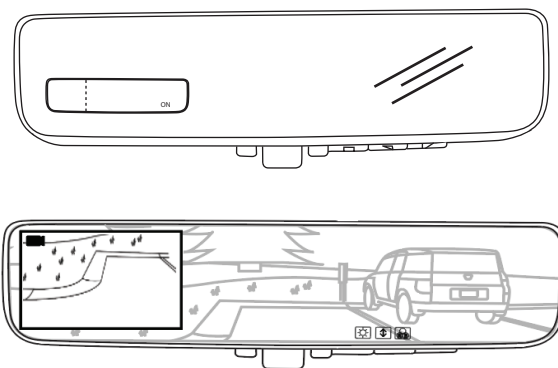

If you would like to add a secondary camera via NTSC input you will need to activate the mirror's secondary camera display. To do this, flip the toggle switch to mirror mode. Then, hold the farthest button to the right for 23-27 seconds. An image will display indicating the RCD display is now active. This secondary NTSC input is triggered by 12v to pin 8.

31 Testing Auto-dimming Function

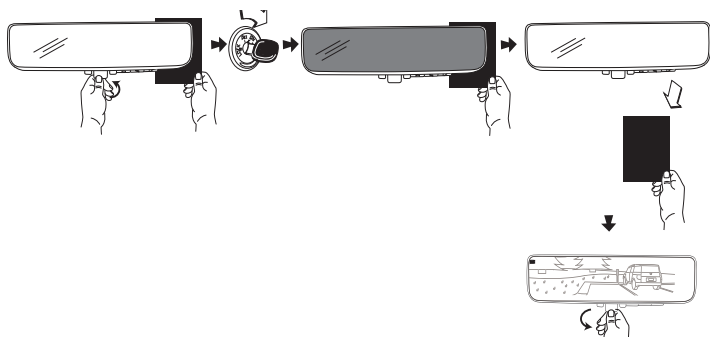

To test dimming function, toggle lever forward towards windshield to place in mirror mode.

While in mirror mode, using a dark cloth or cardboard, completely cover forward-looking sensor. Mirror will dim after a few seconds (depending on light conditions).

Finally, adjust the mirror to standard driving position and toggle lever back towards rear of vehicle to place in display mode. Camera image will appear in mirror.

Connector Pin Out

Cav	Circuit	Color
1	12v PWR	RED
2	GROUND	BRN
3	-	-
4	-	-
5	NTSC(+)	PUR
6	NTSC(-)	ORG
7	-	-
8	12v NTSC Signal	GRY
9	Exterior Mirror(-)	BLK
10	Exterior Mirror(+)	WHT
11	Camera PWR	BLU
12	-	-

