

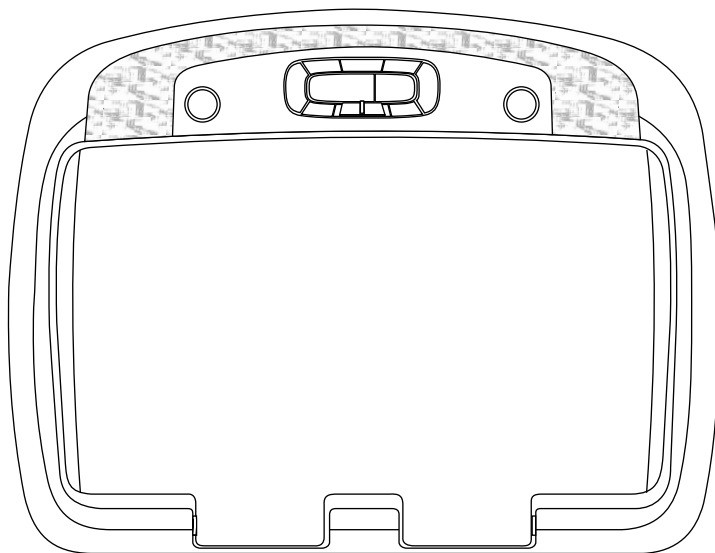

MMD11
11" OVERHEAD LCD MONITOR
WITH DVD PLAYER



Installation Guide

Important Notice

An LCD panel and/or video monitor may be installed in a motor vehicle and visible to the driver if the LCD panel or video monitor is used for vehicle information, system control, rear or side observation or navigation. If the LCD panel or video monitor is used for television reception, video or DVD play, the LCD panel or video monitor must be installed so that these features will only function when the vehicle is in "park" or when the vehicle's parking brake is applied.

An LCD panel or video monitor used for television reception, video or DVD play that operates when the vehicle is in gear or when the parking brake is not applied must be installed to the rear of the driver's seat where it will not be visible, directly or indirectly, to the operator of the motor vehicle.

Important Note

The MMD11 incorporates two new features:

- 1) A wireless FM Modulator
- 2) Snap on Covers with matching Trim Rings (Shale and Pewter). Select the color that matches the interior trim.

Please be advised that the wireless FM modulator will perform well in most applications. However, in certain applications the quality of the wireless signal may be less than optimal, resulting in static or strong local station bleed thru. If this is the case, an optional relay box is available. The Audiovox part number is SIRSWB and it plugs into the 1/8" jack located next to the FM antenna on the side of the chassis. This relay box is installed between the vehicle antenna and the car radio to provide the best possible FM reception of the DVD player audio. When the SIRSWB is installed it is recommended that the wireless FM antenna that is plugged into the printed circuit board next to the 3.5mm jack be unplugged.

MATERIALS INCLUDED IN THIS PACKAGE:

- | | |
|---|-----------|
| 1) 11" TFT LCD Overhead Monitor With DVD Player | - (1pc) |
| 2) 12 Pin Power / Signal harness (P/N 112-3483) | - (1pc) |
| 3) 2 Pin Power Wire Harness with choke (P/N 112B3143) | - (1pc) |
| 4) 9 Pin ~ 3 RCA Jack Pigtail (P/N 112-3682) | - (1pc) |
| 5) Hardware Package | |
| Screws ISO 3 x 6mm Long | - (10pcs) |
| #8 x 3/8" Self Drilling Screws | - (4pcs) |
| M5 Screws | - (4pcs) |
| 6) Remote Control (P/N 136-4196) | - (1pc) |
| 7) Universal Mounting Bracket (P/N 108-3930) | - (1pc) |
| 8) Pry Tool (P/N 100-2424) | - (1pc) |
| 9) Trim Ring - Shale (P/N 102-4244) | - (1pc) |
| - Pewter (P/N 102-4245) | - (1pc) |
| 10) Snap On Cover (Shroud) - Shale (P/N 102-4248) | - (1pc) |
| - Pewter (P/N 102-4249) | - (1pc) |

Optional Accessories

- | | |
|--|---------|
| 11) Wireless Headphones (P/N MMIRHSNL) | - (2pc) |
| 12) SIRSWB Relay Box (P/N 112C3159) | - (1pc) |

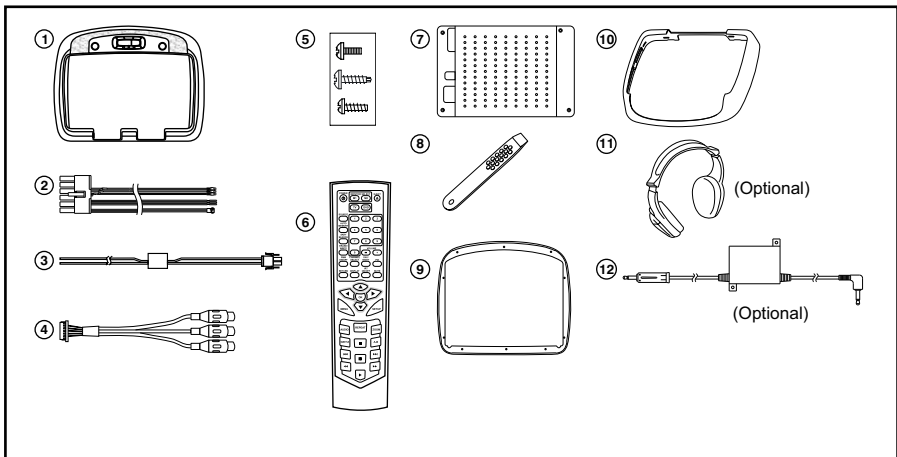

TOOLS REQUIRED:

- #2 Phillips Screwdriver
- #1 Phillips Screwdriver
- Utility or Razor Knife or Shears
- Wire Strippers
- Upholstery hook tool (for removal of panels as necessary)
- Electrical Tape
- Masking Tape
- Multimeter (to verify 12 volt DC and continuity: Do not use a test light or logic probe)
- Marker pen – to mark headliner
- Scribe (to mark trim ring if used)
- Misc. electrical connectors (to connect to vehicle power source). Requirements will vary from vehicle to vehicle)
- DVD Movie (to verify system operation after installation)

Installing The Snap On Covers

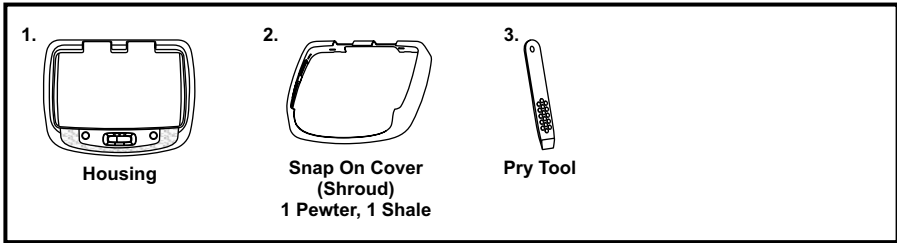

Place the pod on a soft surface to avoid damaging the plastic.

Installing The Shroud

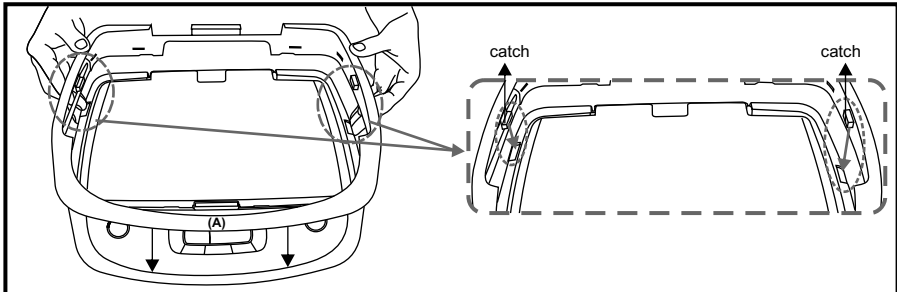

Begin by hooking area "A" (above) over the dome light and slide the cover over the pod. The cover will snap in place.

Removing The Snap On Cover (Shroud) From The Housing

Work on a soft surface to avoid damaging the plastic. Insert the supplied **pry tool** between the Housing and **Snap On Cover (Shroud)**, then press the **pry tool** to release the **Snap On Cover (Shroud)**.

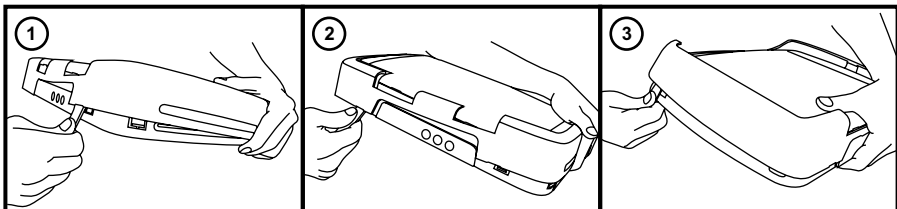

GENERAL INSTALLATION APPROACH:

- 1) Decide upon system configuration and options that will be installed (i.e.: what components, VCP, Video Game, external amp, wireless headphones, VCP, etc.).
- 2) Review all manuals to become familiar with electrical requirements and hook ups.
- 3) Decide upon mounting locations of all components and method of mounting.
- 4) Prep the vehicle by removing any interior trim necessary to gain access to vehicle's wiring as well as all areas where interconnecting wire harnesses will need to be located. If any access holes need to be cut into the vehicle (headliner, other trim components etc.), this should be done now as well.
- 5) Route the wiring harnesses throughout the vehicle as necessary. (Refer to the Wiring Diagrams on this manual as well as the wiring instructions for the individual components and accessory options being installed). Be sure that all wiring is protected from sharp edges and is routed in such a manner that pinched when all components and interior trim are fully installed. Be sure to leave enough slack in the wiring at each component to allow working room.
- 6) Remove all A/V system components from their packaging and place them loosely in the vehicle at their respective locations.
- 7) Connect all components together (electrically) and verify proper operation of all system functions.
Note: This is best done BEFORE, components have been permanently mounted.
- 8) After verifying proper operation of the system, proceed to mount of each component.
- 9) When all components are mounted, recheck function of entire system again to ensure that no wiring was pinched or connected improperly during final installation.

VEHICLE PREPARATION:

- 1) Locate an accessory power source (+12v when key is in the ACC. and run positions, and 0v when key is off), and also a good ground generally, these wires can be found at the ignition switch or fuse-box.
- 2) The mounting method and location will vary from vehicle to vehicle, so this manual will only focus on the installation of the MMD11 and related console accessories.
- 3) Generally, the best location for the video monitor is where the vehicle's factory dome light is installed. The monitor should be located in such a manner that it can be comfortably viewed by rear seat passengers.
NEVER INSTALL THE MONITOR IN A PLACE WITHIN THE DRIVER'S VIEW. THIS IS NOT ONLY DANGEROUS, BUT IT IS ALSO ILLEGAL IN MANY STATES.
- 4) Once the mounting location of the monitor has been determined, there may be additional preparation work necessary, depending on the vehicle structure and installation method. Some of the steps that may be required are:
 - A) Removal of the vehicle's dome light
 - B) If the trim ring will be used, it may have to be trimmed to fit the contour of the vehicle's headliner. Refer to the "Trim Ring Installation" section in this manual.

TRIM RING INSTALLATION:

Note: This page only covers special installation considerations for thick trim ring installation. If the video monitor is to be installed in a vehicle with the thick trim ring, it may need to be trimmed to fit the contour of the vehicle Head liner.

Note: The trim rings supplied with this unit are not designed to be trimmed.

- 1) In this installation, the video monitor is mounted directly to the overhead cross-member in the roof using the mounting screw bosses. These screw bosses should contact the cross-member directly (i.e.: no gap between the screw boss and the roof structure). Also, be sure that the screws do not pierce the outer roof skin when fully fastened to the cross-member. The trim ring is attached to the video monitor using the perimeter screw bosses. It is important that the screws used in this installation are not over tightened, and that the video monitor and trim ring are mounted in such a way that the assembly does not distort (or bend) when the mounting screws are tightened. An alternate method is to use the mounting bracket. First secure the mounting bracket to the cross-member, then screw the monitor into the mounting bracket. See the drawing in this manual.
- 2) It is best to mount the video monitor to the roof structure without the trim ring first. There should be a gap between the headliner and the outer flange of the video monitor. The trim ring should be cut to fill this gap. Apply masking tape to the outer surface of the trim ring in the areas where the cut will be made.
- 3) Mark the cut to follow the necessary contour of the roof. The suggested method of marking is as follows:
 - A) First mark the narrowest point of the trim ring on the masking tape. Be careful to consider not only vertical location, but fore-aft location.
 - B) Using the handle of a screwdriver, make a "transfer marking tool". See diagram below. Place the tool against the roof and the marker against the masking tape on the trim ring. Trace the cut to be made around the entire perimeter of the trim ring.
 - C) Cut the trim ring using a sharp utility knife or shears. Make the cut in several passes over the marked line, each time cutting a little deeper. It is not necessary to cut completely through the plastic, the cut only need be over 50% of the wall thickness of the plastic. By bending the cut back and forth several times, the plastic will break cleanly at the cut.
 - D) Check the fit of the trimmed console and make any minor adjustments necessary.
- 4) The trim ring can be painted or covered with a material that matches the head liner before assembling the trim ring to video monitor.
- 5) The finished trim ring should be attached to the video monitor, then attach the assembly to the roof.

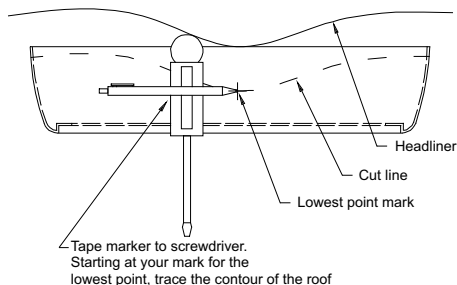

MOUNTING THE TRIM RING

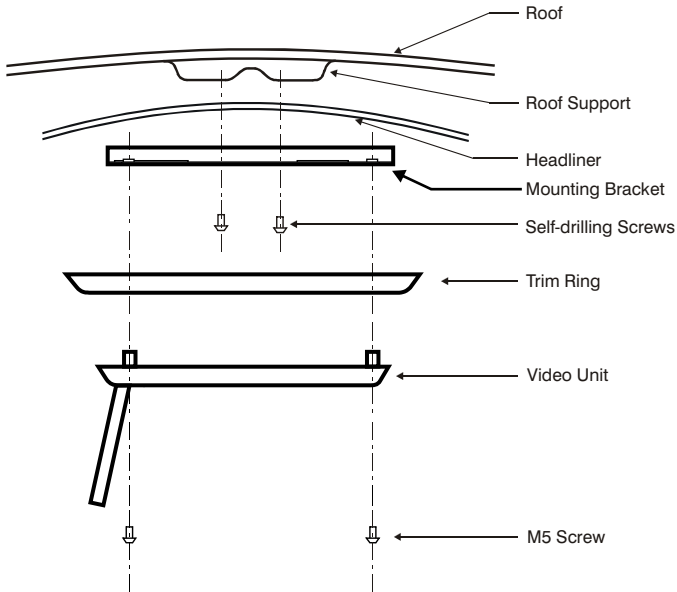

MMD11

- 1) Make the connections to the vehicle for the 12 pin wiring harness.
- 2) Connect power harness to vehicle's electrical system by tapping into an accessory hot line and a good ground.
- 3) Connect the 12 pin harness to the mating connector on the Video Monitor.
- 4) Verify all functions of the System before final mounting of the finished assembly.

A/V Source Definitions:

1. DVD – Built in DVD
2. AV1 – Supplied 9 Pin to 3 RCA Jack Pigtail is used for VIDEO 1 input.
3. AUX – AUX

***NOTE:** If the optional relay box P/N SIRS WB is installed, it is recommended that the antenna for the wireless FM Modulator be unplugged. See MMD11 Wiring Diagram (Figure A) for antenna location.

****NOTE:** Extending the wireless antenna beyond its 12 inch length will cause the FM Modulator to exceed FCC limits for wireless transmission. When installing the unit position the antenna for best reception.

MMD11

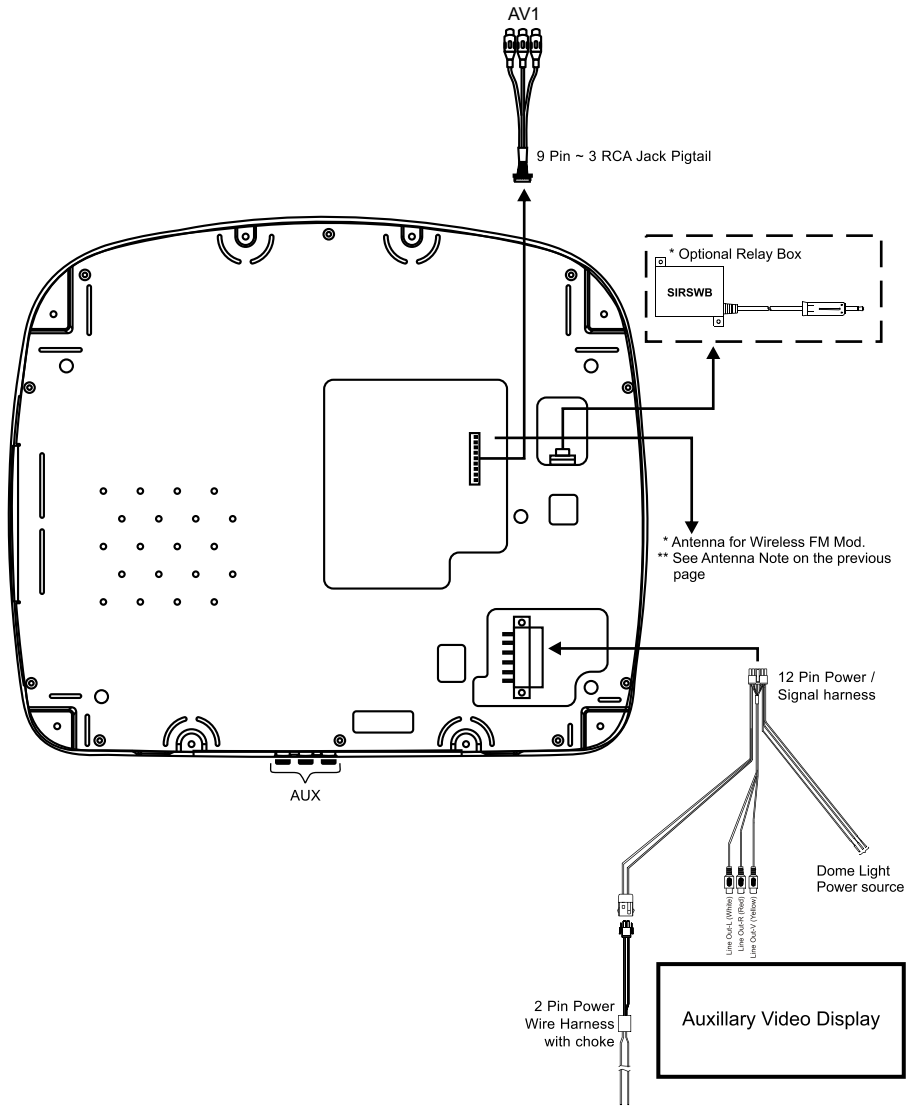

Figure A

CONNECTING THE DOME LIGHTS

The dome lights in the video monitor require three connections to the vehicle's wiring. There are two common types of dome light circuits used, positive or negative switched. Positive systems supply voltage to the interior lights to turn them on, negative switched systems apply ground to illuminate the bulbs. To determine which system you have you must locate the wires at the dome light. On a positive switched system, with all the doors closed and the lights out, both wires at the dome light will rest at ground. When the light is activated, one of these wires will switch to +12 vdc. This is the vehicle's switching wire. On a negative switched system, with all the doors closed and the lights out, both wires at the dome light will rest at + 12vdc. When the light is activated, one of these wires will switch to ground. This is the switching wire.

For positive systems, connect the purple / brown (Lamp auto) wire to the vehicle's switched wire. Then connect the red / black (lamp on) wire to a fused constant 12 volt source and the black / red (lamp common) wire to a good ground. Positive systems are commonly found on Ford vehicles.

For negative systems, connect the purple / brown (Lamp auto) wire to the vehicle's switched wire. Then connect the red / black (lamp on) wire to a good ground and the black / red (lamp common) wire to fused constant 12 volt source. Negative systems are commonly found on General Motors and import vehicles.

Note: Some vehicles which incorporate transistorized control of the dome light circuit, such as the 1999 Dodge Caravan, may require that the purple / brown (Lamp auto) wire be connected to the door pin switch wire, as the additional current draw of the Monitor's lights may not be supported by the output of the vehicles body control computer.

Positive Switched Dome Lighting

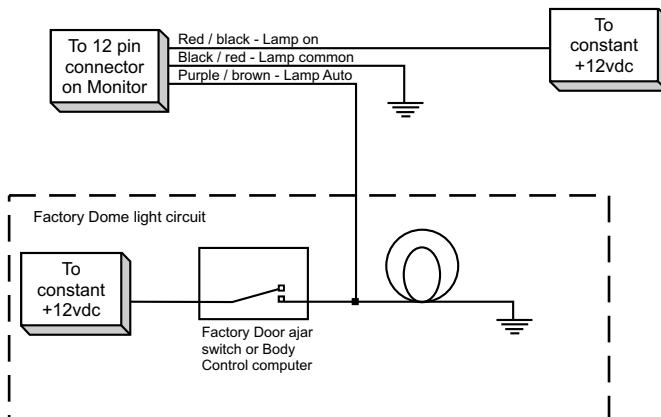

Negative Switched Dome Lighting

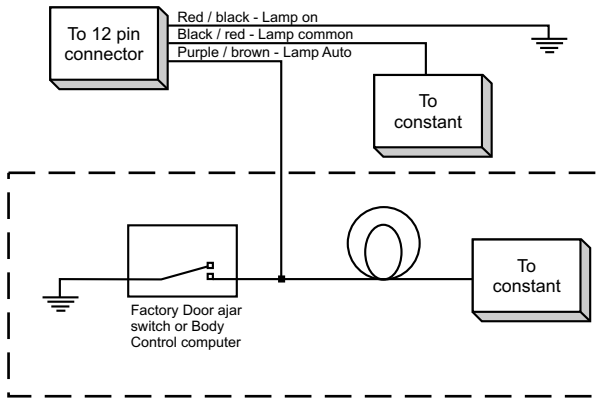

Troubleshooting:

SYMPTOM:

No power at Video Monitor

REMEDY:

Verify +12 VDC on Red wire at 2 pin Power Harness behind video monitor. Verify ground connection with continuity test from known good ground to black wire at 2 pin Power Harness

Power but no video or sound

Verify that the correct source is selected (i.e.: 1,2,3 or 4). Verify that the source is on and playing a known good media (such as a videotape). Verify connections at both ends of the source component harness.

**Static on TV Stations
(Tuner Version Only)**

Press Auto Program button. Then press CH up or CH down. Verify antenna mounting and connections to the tuner.

Note: Due to the nature of TV signals, vehicle motion, direction the vehicle is facing, distance from the transmitter, nearby surroundings and weather may adversely affect TV reception. These conditions may result in the following: picture roll, "snowy" picture, or momentary loss of color.

**No Infrared remote functions
for VCP (or other components)**

Check batteries in the hand held remote. Verify that the IR LED (page 9 Wiring Diagram) is properly attached to the sensor window of the VCP (or other component).

