

# OM DESIGN SERIES MANUAL



*Mirage*<sup>®</sup>



# OM DESIGN SERIES MANUAL

---

## CONTENTS

1.0 GENERAL INFORMATION	1
2.0 GETTING STARTED	3
Unpacking	
3.0 INITIAL PLACEMENT AND MOUNTING INSTRUCTIONS	5
OMD-28	
OMD-C2	
OMD-R	
4.0 CONNECTING YOUR SPEAKERS TO THE SYSTEM	8
Standard connection	
Bi-wire method	
Tri-wire method	
Bi-amp/Tri-amp	
5.0 MULTI-CHANNEL AUDIO SET-UPS	12
6.0 BREAK-IN PERIOD	12
7.0 FINE TUNING YOUR AUDIO SYSTEM	13
General Recommendations	
How to fine-tune the low frequency performance	
How to fine-tune the imaging	
How to fine-tune the soundstage depth	
How to incorporate acoustic room treatments	
Additional requirements for Surround Sound Set-ups	
8.0 INSTALLATION OF THE FEET	15
9.0 CLEANING AND CABINET CARE	16
WARRANTY INFORMATION (BACK COVER)	

---

# OM DESIGN SERIES MANUAL

---

## 1.0 GENERAL INFORMATION

### MIRAGE OM DESIGN SERIES

Please take the time to read all of the instructions contained in this manual to make certain your system is properly connected and functioning correctly. Please retain the carton and packing materials for this Mirage product to protect it in the event it ever has to be shipped to a service center for repairs. Product received damaged by a service center that has been shipped by an end user in anything other than the original packaging will be repaired, refurbished, and properly packaged for return shipment at the end user's expense.

### INTRODUCTION

We are proud to welcome you as a new owner of a Mirage speaker system. The finest components and materials are manufactured to exacting standards and tested with sophisticated manufacturing and quality control techniques to ensure exceptional performance that is superior to speakers costing several times their price. This approach to the development of the Mirage OM Design has resulted in a significant improvement over other system designs in terms of performance and aesthetics.

### COMPANY BACKGROUND

Mirage loudspeakers and subwoofers are designed and manufactured by Audio Products International Corp., known throughout the industry as "API". A Canadian company founded in 1973, API is one of the world's largest speaker manufacturers, supplying products worldwide.

The renowned Mirage research team advances its speaker development through the use of computer-based design techniques combined with multiple listening rooms and anechoic chambers. A dedicated team of engineering, marketing, and manufacturing people creates the finest speakers in the world for your ultimate music or home theater listening pleasure. Now it's time to set up your system and experience the miracle of Mirage Omnipolar sound.

### WHAT EXACTLY IS OMNIPOLAR?

Omnipolar technology uses natural room reflections to create a greater sense of realism. This is accomplished by recreating the same ratio of direct to reflected sound - 70% reflected and 30% direct, that is typically found in performance spaces. A conventional speaker only produces 30% reflected sound. It is the additional reflected sound provided by a Mirage Omnipolar speaker that creates a miraculous three-dimensional sound experience in your home.

# OM DESIGN SERIES MANUAL

## 1.0 GENERAL INFORMATION

### OM DESIGN SERIES OVERVIEW

The OM Design series consists of three different models, the OMD-28, the OMD-C2 and the OMD-R. The following drawings show the three different models with their respective dimensions. This information may be useful when deciding on the initial positioning of your new speaker system:

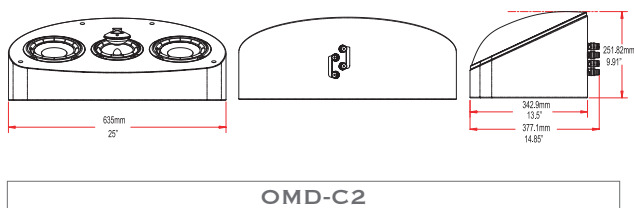
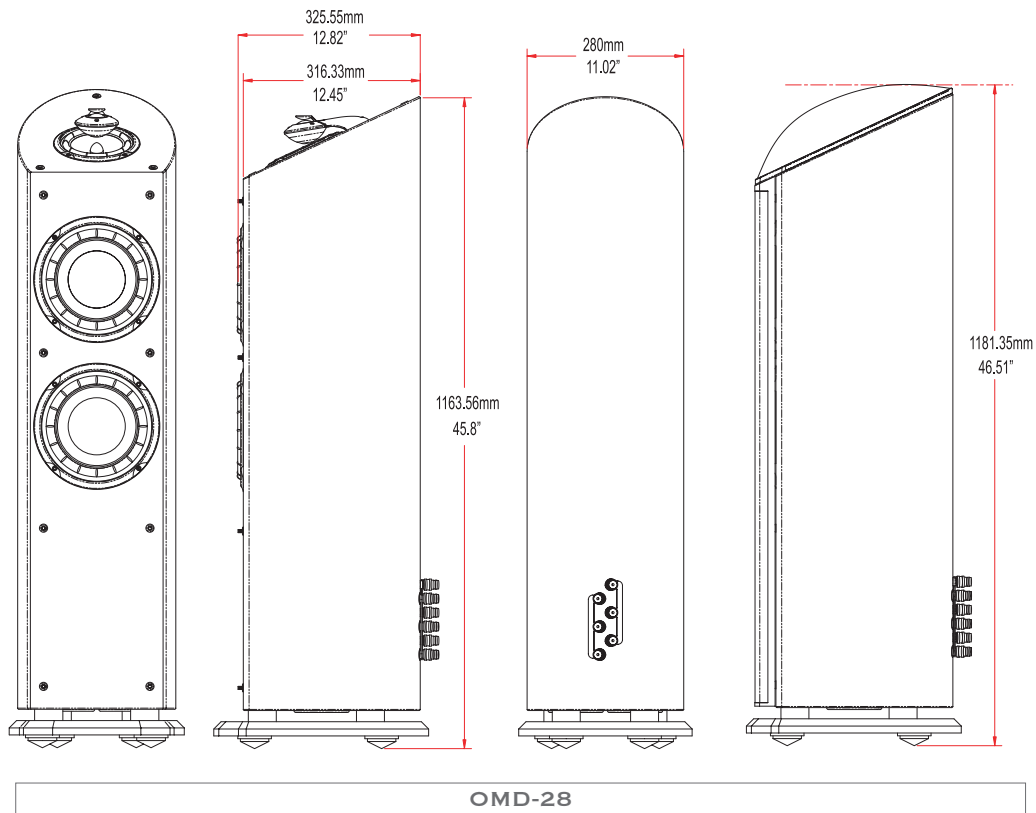
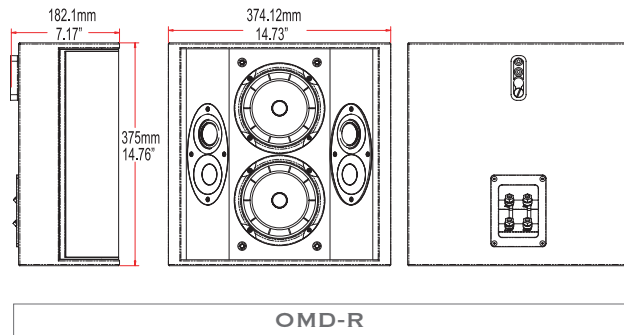

# OM DESIGN SERIES MANUAL

## 2.0 GETTING STARTED

### PACKAGING

The packaging of the OM Design series was specifically designed to ensure the safe transportation of your new speakers. If the packaging has been damaged during shipping, please contact your dealer or shipping company immediately. Please read the following instructions carefully to avoid damaging the speaker cabinets during the installation process.

### INCLUDED IN THE BOX

Included in the box is an accessory case with essential accessories. We highly recommend that you do not throw out any of the items found in the box, as they may be needed at a later point in time. The following items are included in the accessory case:

- 4 feet (OMD-28 only)
- 1 lint free cleaning cloth
- 1 pair of gloves to protect the cabinet finish (2 pairs are included with the OMD-28)

In addition to the above, the OMD-R comes equipped with a versatile and easy to use wall bracket that can be found in the corner of the foam packaging which protects the cabinet during the shipping process.

### UNPACKING

When removing any of the OM Design models from their respective packaging, please make sure to use the supplied gloves in order to protect the beautiful finish on your new speakers. We strongly recommend using the gloves whenever you need to move or reposition the speakers. This will ensure that the flawless fit and finish of your new speakers lasts for many years to come.

### OMD-28

**CAUTION: HANDLE WITH CARE. THE HIGH-GLOSS FINISH ON YOUR OMD-28 SPEAKER CABINETS CAN EASILY BE SCRATCHED. DUE TO THE SIZE AND WEIGHT OF THE SPEAKERS, AT LEAST TWO PEOPLE SHOULD BE AVAILABLE FOR THE UNPACKING AND INSTALLATION PROCESS!**

To remove the OMD-28s from the shipping box, carefully follow these steps:

1. Keep the shipping box in an upright position, with the arrows pointing upwards. Cut the 2 bands of plastic strapping that secure the shipping box.

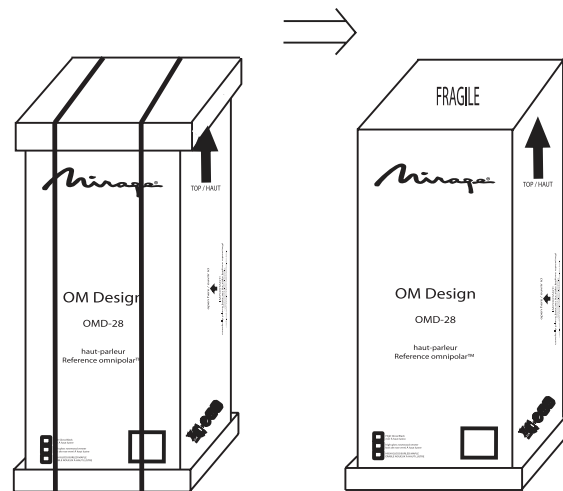

# OM DESIGN SERIES MANUAL

---

## 2.0 GETTING STARTED

2. Remove the protective cover from the top of the box, and tip the box on its side, so that the side marked with "open here" is pointing upwards.

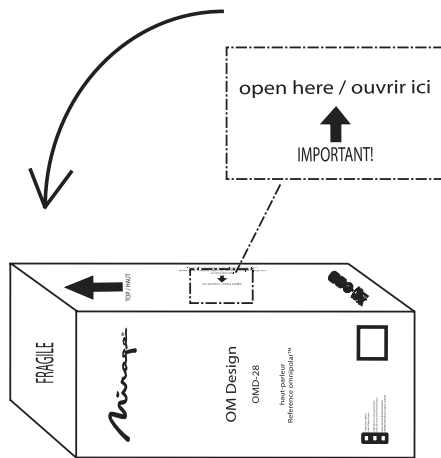

3. Remove the manual and the accessory kit which will be visible upon opening the carton. Unpack the protective gloves contained within the accessory kit and use them for any of the following unpacking and installation steps.
4. Remove the foam packing by gently lifting the packing straight up and out of the interior cardboard box. You will now see the OMD-28 wrapped in protective material, positioned on a bottom layer of foam packaging.
5. Remove the top grille from the foam packaging before removing the cabinet!
6. Lift the OMD-28 out of the shipping box by grasping the base of the loudspeaker's sides and carefully stand the loudspeaker onto its high gloss base. Do not use the binding posts to lift the loudspeaker.

---

**NOTE:** THE OMD-28 WEIGHS APPROXIMATELY 75 POUNDS. PLEASE USE CAUTION WHEN LIFTING THE SPEAKER FROM IT'S PACKAGING.

---

# OM DESIGN SERIES MANUAL

---

## 3.0 INITIAL SPEAKER PLACEMENT

### OMD-28 FRONT SPEAKERS

For best stereo imaging, the left and right speakers should be the same distance from their respective sidewalls. If the distance from one speaker to the listener is very different from the other it can affect the soundstage or stereo imaging. Therefore, the ideal position is having the speakers equidistant to the listener.

When choosing the position for your new speakers, try to avoid walls with predominately glass surfaces, as they might not be the best choice for placement. If it is unavoidable to position the OMD-28s close to a glass wall or a large window, it may result in a hard sound with too much reflected information.

---

**NOTE:** DO NOT INSTALL THE FEET TO THE OMD-28 UNTIL YOU HAVE COMPLETED THE BREAK-IN AND FINE-TUNING PROCEDURES. REPOSITIONING THE SPEAKERS WITH THE FEET INSTALLED CAN BE VERY DIFFICULT AND COULD POTENTIALLY CAUSE DAMAGE TO YOUR FLOORS.

---

A general guideline for speaker placement is to set up the space between speaker and listener at approximately 1.2 to 1.5 times the distance between the speakers. For example, if the speakers are ideally placed a minimum of 6-feet (1.8m) apart, the best seating position would be 7.2 to 9-feet (2.16 to 2.4m) away.

Start with the speakers slightly toed in towards the listening area, ideally 2-4 feet from the rear wall and 3-4 feet from the sidewalls, depending on the width of the listening room.

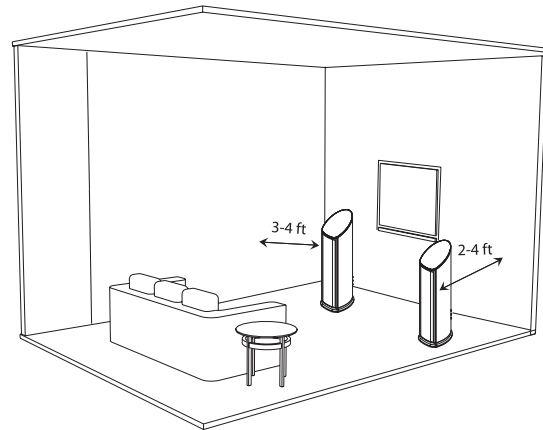

Do not attempt to fine-tune your audio system yet. This should only be done once the break-in procedure is finalized.

# OM DESIGN SERIES MANUAL

## 3.0 INITIAL SPEAKER PLACEMENT

### OMD-C2 CENTER CHANNEL

The OMD-C2's Omnipolar technology is uniform in dispersion, providing a perfectly spherical, full spectrum sound radiation pattern that greatly expands the prime listening area.

The center channel should be positioned at or slightly below ear level. If possible, try to leave a little bit of space behind the OMD-C2. This will aid in producing an open soundstage. It is not recommended to place the OMD-C2 on top of a large rear-projection style television set, as this could negatively impact the sound quality.

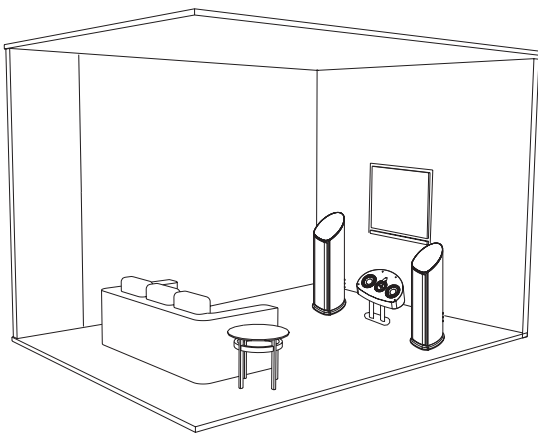

The OMD-C2 is magnetically shielded, and it can be placed close to a CRT based television without causing any interference. In the case where there is some minor discoloration, simply move the speaker forward or backwards or away from the television a few inches, this generally resolves the issue.

**NOTE: LCD, DLP AND PLASMA DISPLAYS DO NOT SUFFER FROM MAGNETIC INTERFERENCE.**

The best performance can be achieved by using the matching OMD-C2 stand as it offers the perfect height for the OMD-C2 center channel. Please visit [www.miragespeakers.com](http://www.miragespeakers.com) for more information on this stand.

### OMD-R

The rear speakers can vary greatly in position depending on the room layout, and the furniture placement. The ideal position is either on the sidewalls, or rear walls.

**Side Wall:** This position utilizes the rear walls of the room to reflect sound and create the "surround" effect. **Rear Wall:** This is generally used when the sidewall position is not available to you, due to furniture placement or room dimensions. It is also used in a 6.1 or 7.1 surround configuration. Both mounting positions have their advantages and disadvantages, the position offering the best coverage of the entire room should be chosen. The goal of the surround speakers during movie reproduction is to create an "atmosphere" around you. The rear channel speakers are ideally placed an equal distance from you as compared to the front speakers. But this is not always possible in a home environment. The OMD-R will emit sound from both sides of the speaker, and is best placed where it can use the walls to reflect the sound around the listeners. The best mounting position for a 5.1 system is the Side Wall position, as it makes use of the rooms' rear walls, and sidewalls. It will create a lifelike surround effect and make the room sound larger than it is. In this position, try to mount the speaker so that it is beside you or slightly behind you. The height should be above ear level, at approximately 2/3 of the height of the wall. 6 feet off of the ground is typically a good starting point, and the speaker should be 2 feet above your head when seated. These general guidelines should aid in positioning choices.

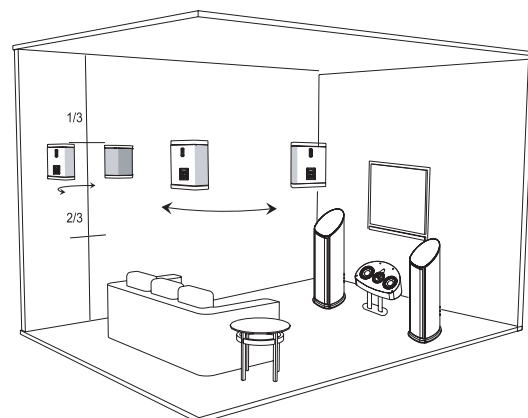



# OM DESIGN SERIES MANUAL

## 3.0 INITIAL SPEAKER PLACEMENT

You can also achieve excellent results in the rear position. Try not to place the speakers directly into a corner. Leave 2 or more feet between the edge of the cabinet and the sidewall, so the sound can reflect into the room environment. The rear position is usually chosen when your room will not accommodate the sidewall position due to unequal walls, a doorway, or a large opening, etc. It is recommended that the rear center (6.1 system) or dual rear surrounds (7.1) be placed at the same height as the other two rear surround speakers wherever possible.

### MOUNTING YOUR OMD-R SPEAKERS

**NOTE:** THE OMD-R FEATURES A VERY SIMPLE WALL MOUNTING SYSTEM. CAREFUL ATTENTION MUST BE MADE TO MOUNT IT SECURELY AS THE SPEAKER IS HEAVY AND DAMAGE TO THE PRODUCT AND/OR INJURY COULD RESULT FROM IMPROPER MOUNTING. PLEASE FOLLOW THE DIRECTIONS CAREFULLY!

**NOTE:** THE MOUNTING HARDWARE FOR THE OMD-R CAN BE FOUND ON TOP OF ONE OF THE PROTECTIVE FOAM PIECES INSIDE THE SHIPPING CARTON. THEY ARE TAPED INTO ONE CORNER, AND SHOULD BE VISIBLE WHEN YOU OPEN THE OMD-R PACKAGING.

1. Select the mounting position best suited for your room.
2. Place the wall-mounting bracket against the wall in the desired mounting location and mark the center of the two holes with a pencil. This is where you need to insert the appropriate mounting hardware to securely fasten a load of 22 lbs. Hardware is not included with the speaker, as building materials vary greatly in different countries, but the recommended screw head size is a #8. Screw length is to be determined by the wall material.

3. If you are mounting directly to drywall, please ensure that you use the appropriate anchors, as screws into drywall itself will not provide a secure mount. Insert the anchors, and then hold the mounting bracket up to the wall. Insert the screws until tight. Try to locate into wall studs wherever possible.

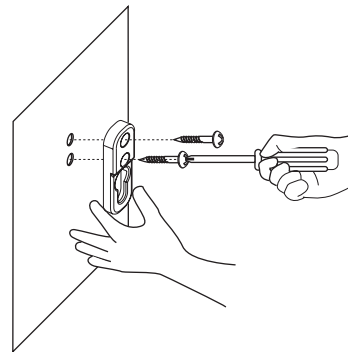

4. Screw the included bolt into the insert in the back of the OMD-R speaker, located above the terminal cup. Hand tighten the bolt all the way, and then loosen a few turns counter clockwise. Place the two included rubber bumpers on the back of the speaker, on either side of the back label.

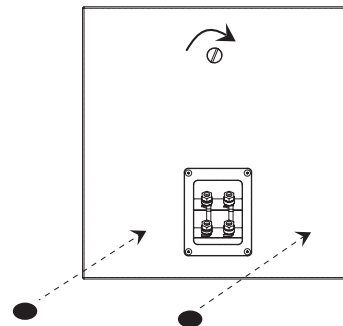

5. Hold the speaker upright, and insert the bolt head into the large hole. Let the speaker slide down into place.

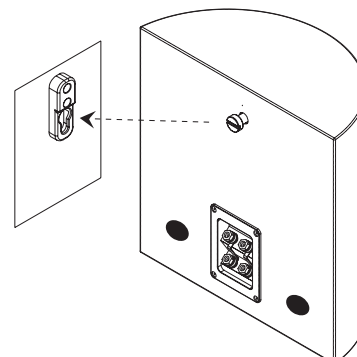

# OM DESIGN SERIES MANUAL

---

## 4.0 CONNECTING YOUR SPEAKERS

### CABLES AND AMPLIFICATION

Use the best quality speaker cables you have available. The length and type of speaker cable used in your system can have an audible effect and allow you to maximize the transmission of power from your amplifier to the speakers.

We recommend, if possible, that short runs of speaker cable connect the power amplifier(s) and speakers and that high-quality long interconnect cables be used to connect the preamplifier and power amplifier. This results in the power amplifiers being close to the speakers, which may be practically or cosmetically difficult. However, if the length of the speaker cables can be reduced to a few meters, sonic advantages may be obtained.

---

**WARNING! Turn your amplifier off before making or breaking any signal connections!**

---

### CONNECTING YOUR SPEAKERS TO YOUR SYSTEM

All of the models in the OM Design Series feature high quality gold plated binding post connectors. The OMD-R uses a slightly different design of binding post connectors than the other models in this series, allowing the speaker to be mounted flush to the wall. The functionality of all connectors is the same, and as such the following description can be applied to all models.

The OM Design series will accept a variety of connector types including spade lugs, banana plugs, or pin type connectors. The best connector in our opinion is the "Spade lug" as it provides more contact area with the terminal and allows the binding post to be tightened for a secure connection. Audiophiles and novices alike have preferences as to which connector type they favor, speak with your Authorized Mirage retailer as to which is the best for your Audio Video System. Rest assured, plain speaker wire is more than acceptable, you can always upgrade your wires and/or connectors later on.

Remove the plastic red or black insert. The plastic insert is a mandatory security measure, as dictated by many local and federal government associations.

To Connect your speaker system: Start at one speaker, and connect one channel at a time, starting with the front speakers. Always ensure that the entire A/V system is powered OFF before performing any connections. The positive and negative (red and black) sides of the speaker terminals MUST match the positive and negative (red and black) terminals of the receiver or amplifier. If they do not match, abnormal sound and a lack of bass response will result. After connecting the front speakers, connect the rest of the speakers to their appropriate channels of the receiver or amplifier. The three connection methods and their explanations include:

# OM DESIGN SERIES MANUAL

## 4.0 CONNECTING YOUR SPEAKERS

### TRADITIONAL CONNECTION METHOD

1. Using your choice of speaker wire and termination method, connect the speaker cable (minding the positive and negative polarities), to the lower set of connectors. Ensure the terminals are tight. The gold "shorting straps" that connect the lower and upper connections (in the case of the OMD-28, the shorting strap should bridge the lower, middle and upper set of binding posts) must remain in place.
2. Repeat the procedure for the second speaker.

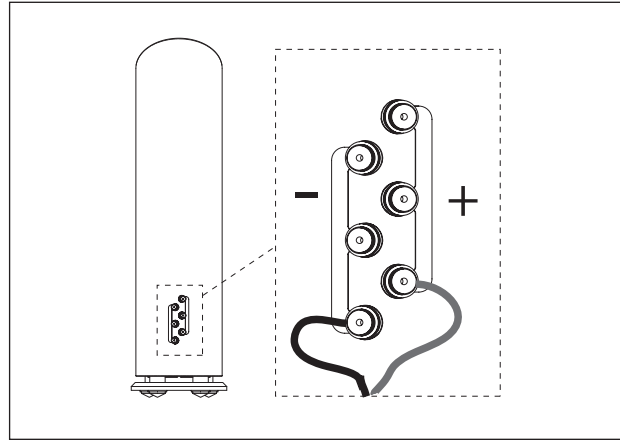

OMD-28

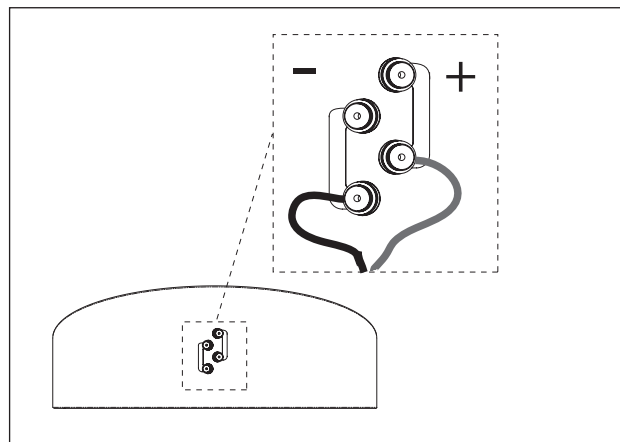

OMD-C2

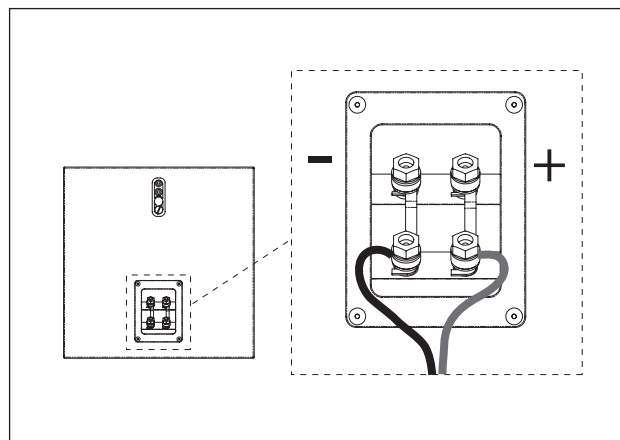

OMD-R

# OM DESIGN SERIES MANUAL

## 4.0 CONNECTING YOUR SPEAKERS

### BI-WIRE METHOD

This method involves using multiple cables and connectors, to access two sets of terminals on the OM Design loudspeakers simultaneously. The benefit of bi-wiring is to reduce noise, as you will have twice the thickness of cable between the amp and speakers as the traditional method would provide. For more details on the benefits of bi-wiring, please discuss this with your authorized MIRAGE® retailer.

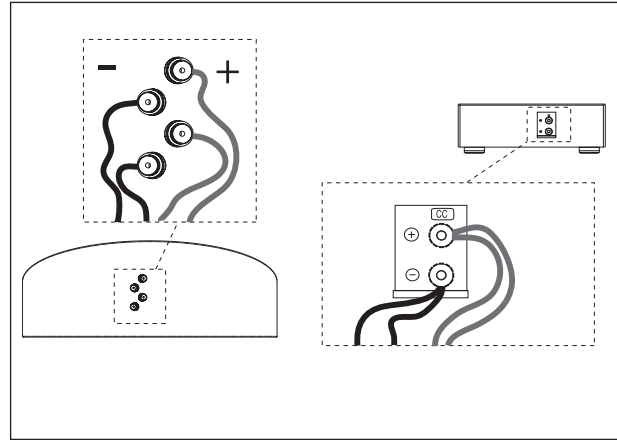

### OMD-R AND OMD-C2

Before starting, remove the gold "shorting straps", which connect the top and bottom set of input terminals. To remove the straps, loosen all of the connectors and pull the straps away from the binding posts. Make sure you put them in a safe place for future use.

Then simply connect two separate set of wires to the four binding posts.

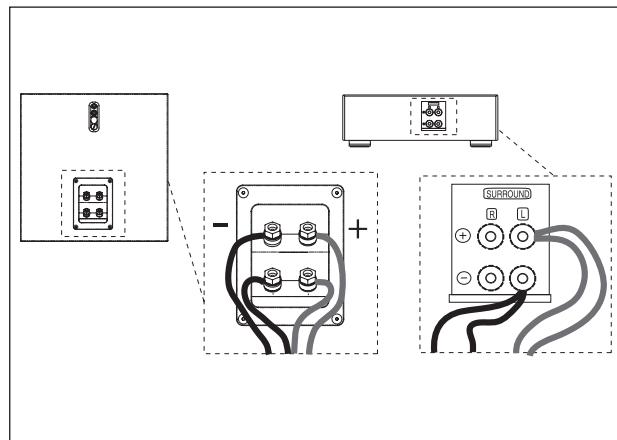



# OM DESIGN SERIES MANUAL

## 4.0 CONNECTING YOUR SPEAKERS

### OMD-28

The OMD-28 is equipped with 3 sets of binding posts which allows the speakers to be tri-wired/tri-amped. The tweeter's terminals are on top, the midrange driver's terminals are in the middle and the woofer's terminals are at the bottom. Gold plated shorting straps are factory pre-installed, one strap to connect the three negative and one strap to connect the three positive terminals.

**NOTE: BOTH STRAPS MUST BE INSTALLED IN ORDER TO USE THE TRADITIONAL CONNECTION METHOD**

In order to bi-wire the OMD-28s, the metal straps can simply be used to bridge two sets of binding posts (instead of three) by moving the straps up or down. To do so, loosen all of the connectors, pull the straps away from the binding posts and reinstall the straps to connect two of the three binding posts. Under normal circumstances, the gold straps should be connected to the middle and top set of binding posts. This way one separate set of cables would be used to drive the two 8" drivers and the other cable would drive the midrange and tweeter.

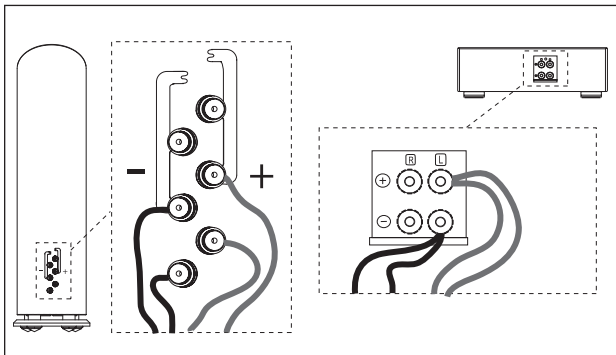

### TRI-WIRE METHOD (OMD-28 ONLY)

In order to tri-wire the OMD-28s, simply remove the binding post straps from the speakers, and connect three separate set of wires to the six binding posts. Please ensure that polarity is maintained when connecting the speaker wires.

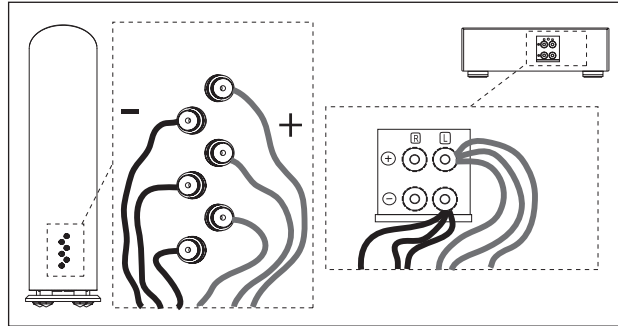

### BI-AMPLIFICATION / TRI-AMPLIFICATION

The OM Design series can also be connected to multiple amplifiers. Two or even three amplifiers in the case of the OMD-28 can further enhance the performance of the OM Design series. However, choosing quality electronics is a crucial part in achieving the full benefit of bi-amping/tri-amping. Please consult your authorized Mirage dealer for recommendations on adequate electronics. Please follow the same steps as described in the section above. Instead of connecting two sets of wires to one amplifier, simply connect one set of speaker wires to each amplifier.

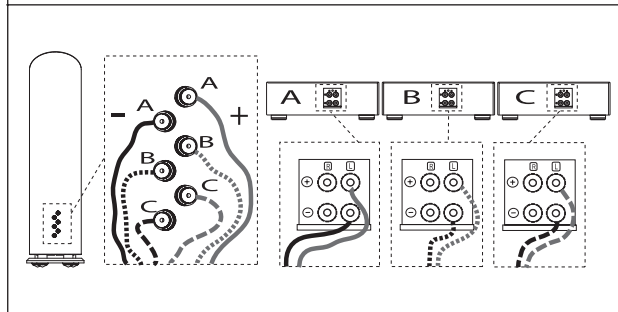
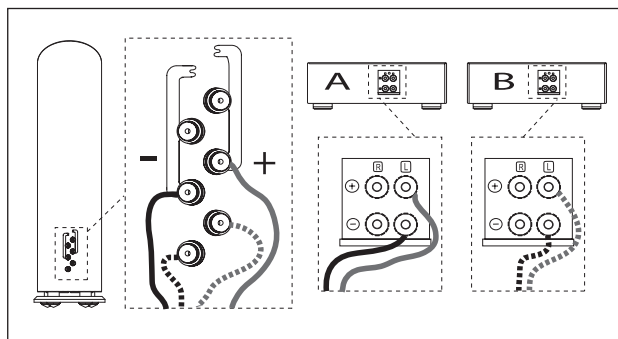

# OM DESIGN SERIES MANUAL

---

## 5.0 MULTI-CHANNEL AUDIO / HOME THEATER SET-UPS

## 6.0 BREAK-IN PERIOD

### MULTI-CHANNEL AUDIO SET-UPS

The OM Design series offers the ultimate in flexibility; it excels at traditional 2-channel stereo set-ups or can provide illustrious multi channel audio / home theater performances. Depending on your particular room layout and your personal requirements the OM Design series can be used for any imaginable multi-channel set-up. Please consult your authorized Mirage dealer for specific recommendations based on your requirements and your room layout.

---

**NOTE:** IN ORDER TO ACHIEVE PERFECT TIMBER MATCHING BETWEEN YOUR MULTI CHANNEL AUDIO SYSTEM, IT IS HIGHLY RECOMMENDED TO USE ONLY MODELS FROM THE OM DESIGN SERIES.

---

### BREAK-IN PROCEDURES

It is VITAL that your new OM Design speakers be allowed to break-in properly before you perform any precise set up procedures, system adjustments, and before you play them at higher volume levels. The best method of performing the break-in is to play a full range musical passage at a moderate level as long as possible. Utilizing the repeat function on your CD or DVD player can assist greatly. Optimum sound will not be achieved until approximately 100 hours of playing time. After break-in, the volume level can be increased. Do not play the speakers at high levels until the break-in process has been completed. The transducers need to "loosen up", and until this occurs, damage can result to the transducers.

# OM DESIGN SERIES MANUAL

---

## 7.0 FINE TUNING YOUR AUDIO SYSTEM

Before beginning any fine-tuning, please ensure all connections are properly made and your speakers have had the chance to break-in for a minimum of 100 hours.

Also, it is assumed that you have already performed the initial placement of each speaker in your system and are now trying to fine tune the performance of your new speakers in your room. This will ensure the proper results are achieved.

### GENERAL RECOMMENDATIONS

Your listening room is the final component of your audio system and will be the difference between mediocre sound and high quality sound. Reflections, which are a part of every recording and music playback, will have a major effect on your system's performance. If your room is too "live", meaning there are many bare surfaces like glass windows, hard floors and thin furnishings, you might find the sound overly bright. If your room is "dead", meaning there is thick pile carpeting, heavy furniture and a lot of wall coverings, you might find the sound lacks dynamic energy. To remedy these issues, small changes to your room should be considered as they generally lead to large improvements in sound quality. Most listening rooms must balance aesthetics and sound, but patience and small adjustments in positioning and settings can pay huge acoustic dividends. The lower bass frequencies are typically the most influenced by your listening room. If you find the bass in your room to be uneven or exaggerated in certain frequencies, experimenting with placement of the front speakers or their orientation towards the listening position can alleviate some of these issues. The proximity of the speakers to room boundaries, like walls, will also affect the bass frequencies.

### HOW TO FINE-TUNE THE LOW FREQUENCY PERFORMANCE

If you find your system lacks bass, first check your connections to make sure your system is in phase, then experiment with placement. The further from the wall, the less overall bass output your system will have, but the bass will generally be better defined. If bass is too prominent, try moving the OMD-28 speakers further from the wall, or spacing them a little further apart from one another.

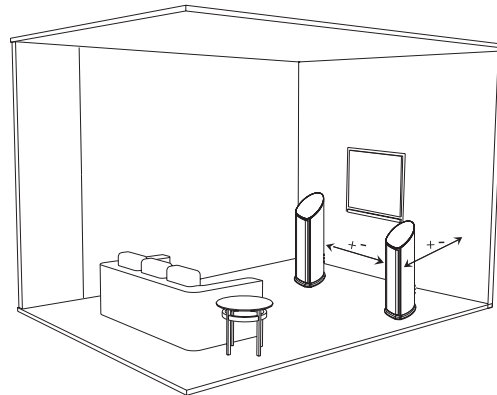

---

**NOTE:** THE BASS PERFORMANCE WILL TIGHTEN UP SIGNIFICANTLY, ONCE THE ISOLATION FEET ARE INSTALLED TO THE OMD-28 FRONT SPEAKERS.

---

# OM DESIGN SERIES MANUAL

---

## 7.0 FINE TUNING YOUR AUDIO SYSTEM

### HOW TO FINE-TUNE THE IMAGING

If you are experiencing issues with imaging, first ensure your speakers are in phase with each other. If this is the case and imaging is still an issue, moving the speakers closer together or toeing them in slightly (angling them towards the listening position) can aid in this respect.

The cone feet can be used to tilt the OMD-28s slightly forward. In certain situations where a lack of image focus was found, this set-up adjustment has proven to be an effective measure to improve image focus.

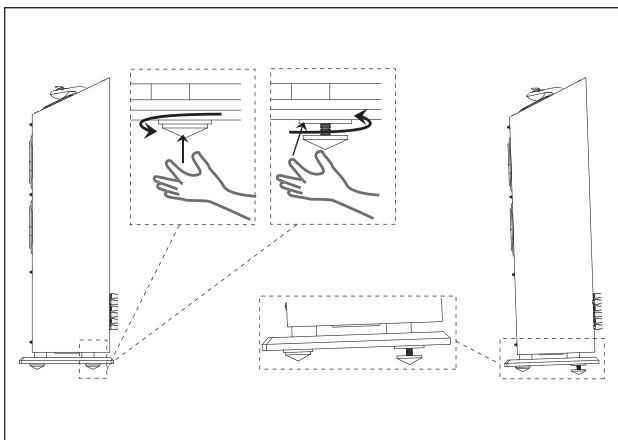

### HOW TO FINE-TUNE THE SOUNDSTAGE DEPTH

The soundstage depth can be adjusted by changing the distance from the speakers to the back and/or the side walls. If your system is lacking soundstage depth, try to move the speakers further away from the back wall. If your soundstage is lacking width, moving the speakers further away from the side wall is a good measure to increase the soundstage width. In the opposite cases, when the soundstage is overly large in either width or depth, try to move the speakers closer to the respective wall.

### HOW TO INCORPORATE ACOUSTIC ROOM TREATMENTS

If the sound has poor focus and seems to be too "splashy" or indistinct sounding, more damping may be required in the listening area. Experiment by adding an area rug between the listener and the front speakers if there is a bare wood floor. Some damping treatment to treat the ROOM, not the speaker reflection points, can work well to reduce this problem. A number of different options are available on the market, damping pads for the corners of the room at the ceiling, pads for the corners of the room, etc. A room can be tested simply by clapping while walking around the room. The sound of the clap should die off smoothly, but not instantaneously. If the clap results in a long standing echo, the room may require some acoustic treatment.

---

**NOTE:** DO NOT ATTEMPT TO ADD DAMPENING MATERIALS TO THE FIRST REFLECTION POINTS OF THE SPEAKERS! OMNIPOLAR SPEAKERS ARE DESIGNED TO EMBRACE SUCH REFLECTIONS AND THEY ARE A CRUCIAL PART IN THE PERFORMANCE OF THE SPEAKERS.

---

### ADDITIONAL REQUIREMENTS FOR SURROUND SOUND SET-UPS

When installing a surround sound system, all the above holds true. Calibration of your speaker distances, adjusting delays and balancing your levels with an SPL meter is recommended to extract the most out of your system.



# OM DESIGN SERIES MANUAL

## 8.0 INSTALLATION OF ISOLATION FEET (OMD-28 ONLY)

Once you have completed the fine-tuning process and have found the ideal position for the speakers in your room, you are ready to install the feet of the OMD-28. In the accessory case you will find four machined aluminum feet.

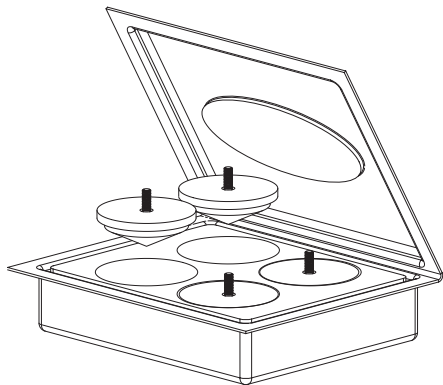

In order to install the feet, please follow these two easy steps:

**NOTE: TWO PERSONS ARE REQUIRED IN ORDER TO SAFELY INSTALL THE FEET OF THE OMD-28.**

1. With one person securely holding the OMD-28 cabinet in place, slightly tip the cabinet towards that person so that the bottom of the base is partially exposed

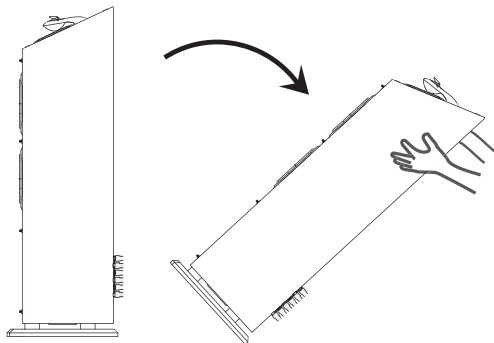

2. The other person can now screw the feet into one of the four the threaded inserts found at the bottom of the base

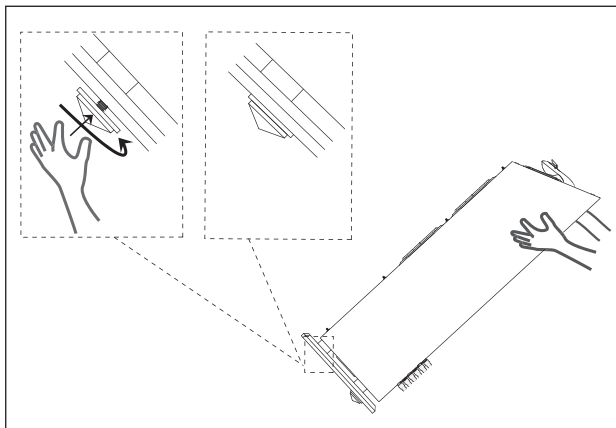

Repeat these steps until all four feet are securely installed.

3. The feet can now be used to precisely level the speaker. Simply unscrew the foot to level the cabinet and then rotate the large washer so that it is snug against the cabinet, NOT the cone foot itself! This will securely lock the foot in position and will not allow it to "rock" on its threads.

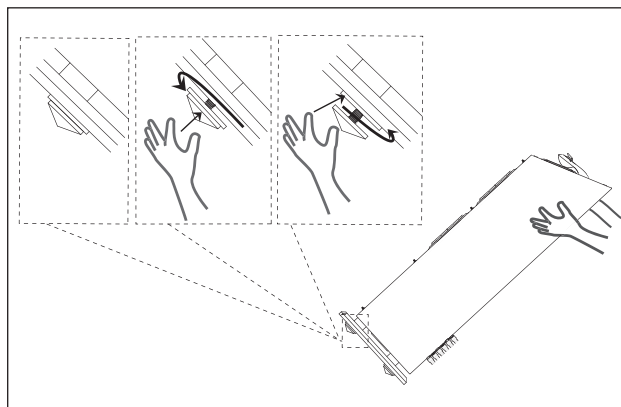

# OM DESIGN SERIES MANUAL

---

## 9.0 CLEANING AND CABINET CARE

The cabinets of your new OM Design speakers are constructed of the finest quality veneers and hardwoods available and are protected with hand rubbed superior quality urethane finishes. Great care should be taken when cleaning the cabinet. Properly maintaining the fine finish will enhance your home's decor and preserve the value of your new speakers for many years to come.

### AVOIDING FINISH DAMAGE

Your OM Design speaker cabinets, like all woodwork, are subject to expansion and contraction with humidity changes. Excessive wood movement can eventually cause the finish to develop tiny cracks and even separate the finish from the wood. Moderating the temperature and humidity swings around the speakers will help to preserve their finish as well as their overall structure.

Try to maintain a fairly even temperature in your listening room. Place the speakers away from drafts, dampness, and heat sources. ALWAYS AVOID DIRECT SUNLIGHT – as sunlight will age the finish prematurely and cause color fading.

### DUSTING YOUR SPEAKERS

Dust is very abrasive, and can scratch the finish if wiped off with a dry cloth. To avoid scratching, dust the speakers lightly with a feather duster. Alternatively, wipe lightly with a soft damp cloth to pick up the dust, followed immediately with a dry cloth. The cloths should be made of soft cotton such as flannel. Coarse or synthetic fabrics can scratch some finishes. A cleaning cloth is supplied in your speaker package.

---

**NOTE: DO NOT TOUCH, OR ATTEMPT TO CLEAN THE METAL DOME TWEETER. IRREPARABLE DAMAGE WILL OCCUR!**

---

### CLEANING THE FINISH.

To remove smudges and fingerprints, first dust as described above. Then use the supplied cleaning cloth to gently clean the speakers. If heavier cleaning is necessary, dampen your cloth with a small amount of mild soap solution.

---

**NOTE: WHEN CLEANING OR POLISHING THE LACQUER FINISH OF THE OM DESIGN CABINET, AVOID HARD PRESSURE TO AVOID SCRATCHES TO THE FINISH.**

---

### TO POLISH OR NOT?

Before using polish on your speakers, be sure it is actually necessary and beneficial. In general, Mirage Speakers recommends against using polishes because of the potential for damage to the finish.

Common household products such as "lemon oil" or inexpensive "furniture polish" should be avoided. Despite the labels' claims that they "protect" the finish or "feed" the wood, they offer no protection from scratching and can actually soften the finish if overused. Aerosol products should be avoided altogether.

Always test a new polish in a inconspicuous area of your speaker – one good location for example would be the area slightly above the binding posts.

---

**NOTE: PLEASE ENSURE THAT POLISHING OR CLEANING SUBSTANCES DO NOT COME IN CONTACT WITH THE DRIVERS OF THE OM DESIGN SERIES, AS THIS COULD PERMANENTLY DAMAGE YOUR SPEAKERS.**

---

If you are uncertain about the care of your speaker's finish, please consult your authorized Mirage dealer.

# OM DESIGN SERIES MANUAL

## WARRANTY

### LIMITED WARRANTY POLICY IN THE UNITED STATES AND CANADA

MIRAGE® warrants this product to the retail purchaser against any failure resulting from original manufacturing defects in workmanship or materials. The warranty is in effect for a period of: Passive Speakers: five (5) years, Powered Subwoofers including the speaker - one (1) year from date of purchase from an authorized MIRAGE® dealer and is valid only if the original dated bill of sale is presented when service is required.

The warranty does not cover damage caused during shipment, by accident, misuse, abuse, neglect, unauthorized product modification, failure to follow the instructions outlined in the owner's manual, failure to perform routine maintenance, damage resulting from unauthorized repairs or claims based upon misrepresentations of the warranty by the seller.

### WARRANTY SERVICE

If you require service for your MIRAGE® speaker(s) at any time during the warranty period, please contact:

1. The dealer from whom you purchased the product(s)
2. Service Centers can be found by checking the MIRAGE® website: [www.sound-dynamics.com](http://www.sound-dynamics.com)
3. MIRAGE® NATIONAL SERVICE  
203 Eggert Road  
Buffalo, N.Y. 14215  
Tel: 716-896-9801 or
4. MIRAGE® a division of Audio Products International Corp.  
3641 McNicoll Avenue  
Toronto, Ontario, Canada M1X 1G5  
Tel: 416-321-1800

You will be responsible for transporting the speakers in adequate packaging to protect them from damage in transit and for the shipping costs to an authorized MIRAGE® service center or to MIRAGE®. If the product is returned for repair to MIRAGE® in Toronto or Buffalo, the costs of the return shipment to you will be paid by MIRAGE® provided the repairs concerned fall within the Limited Warranty. The MIRAGE® Warranty is limited to repair or replacement of MIRAGE® products. It does not cover any incidental or consequential damage of any kind. If the provisions in any advertisement, packing cartons, or literature differ from those specified in this warranty, the terms of the Limited Warranty prevail.

## GARANTIE

### GARANTIE AUX ÉTATS-UNIS ET AU CANADA

La société MIRAGE® garantit cet appareil contre toute défectuosité attribuable aux pièces d'origine et à la main d'oeuvre. Cette garantie est valide pendant une période de cinq (5) ans (enceinte passif) et de un (1) an (extrêmes-graves) à partir de la date d'achat auprès d'un revendeur MIRAGE® agréé ; la garantie ne sera honorée que sur présentation d'une pièce justificative de la date d'achat.

La garantie ne couvre aucun dommage subi pendant le transport ou imputable à un accident, à une utilisation impropre ou abusive, à la négligence, à une modification non autorisée, à la non-observance des instructions décrites dans le manuel de l'utilisateur ou des directives d'entretien, ni aucun dommage subi par suite de réparations non autorisées ou de réclamations fondées sur une mauvaise interprétation des conditions de la présente garantie par le revendeur.

### SERVICE SOUS GARANTIE

Dans l'éventualité où une réparation deviendrait nécessaire pendant la période de couverture de la garantie, communiquez avec :

1. le revendeur auprès de qui l'appareil a été acheté,
2. Pour connaître l'adresse de tous nos centres de service, consultez le site Web de MIRAGE® Speaker Systems à [www.sound-dynamics.com](http://www.sound-dynamics.com)
3. MIRAGE® National Service,  
203, Eggert Road  
Buffalo, N.Y. 14215  
tél. : 716-896-9801 ou
4. MIRAGE® Speaker Systems  
3641 avenue McNicoll  
Toronto (Ontario), Canada M1X 1G5  
tél. : 416-321-1800

Le propriétaire de l'appareil est responsable de son emballage et de tous frais d'expédition à un centre de service athena agréé ou à MIRAGE®. Si l'appareil est expédié à MIRAGE® à Toronto ou à Buffalo aux fins de réparation, les frais de réexpédition seront assumés par athena à la condition que les réparations effectuées soient couvertes par la garantie. La garantie est limitée à la réparation ou au remplacement des appareils fabriqués et distribués par athena. Elle ne couvre aucun dommage indirect ou consécutif de quelque nature que ce soit. Si les conditions accompagnant toute publicité, emballage ou documentation divergent de celles de la présente garantie, les conditions de la présente garantie prévaudront.