



PRO9056Z

Vehicle Remote Start System

Installation and Reference Guide

Thank you for trusting Pursuit products! **If you are a consumer, please note: Professional installation is strongly recommended.**

This manual assumes the installer has adequate knowledge of the following expertise. Therefore, it does not cover these topics in detail:

- **12-volt electronics**
- **Testing and verifying circuits**
- **Making safe and lasting wiring connections**
- **Factory ignition, power, lighting, data bus and sensing systems**
- **Factory systems and components to avoid**
- **Safe wire routing, circuit protection and product placement**
- **Access to vehicle-specific technical information**

In addition, this manual assumes the installer has the **proper tools, skill and facilities** to perform a professional installation. **Performing an improper installation could result in damage to the vehicle or its components, improper system function, unsafe vehicle operation or physical injury.** Such instances would not be covered by the vehicle manufacturer's warranty, nor by Voxx Electronics, Inc.

Detailed Descriptions

2 Wire Harness Colors and Functions

- 2 [Power Connector](#)
- 3 [Notification Connector](#)
- 4 [Input / Output Connector](#)

6 External Components

- 6 [RF Antenna Kit](#)
- 6 [Data Bus Interface \(DBI\)](#)
- 6 [Telematics](#)
- 6 [Weblink Programming](#)

7 Setup Options

- 7 [Remote Programming](#)
- 8 [Keyless Control](#)
- 10 [Remote Start Control](#)

14 System Operation

- 14 [Remote Operation](#)

Quick Reference

15 System Programming

- 15 [Programming Mode Entry / Exit](#)
- 16 [Feature Bank Options](#)
- 17 [Data Port Protocol](#)
- 17 [Tach Function](#)
- 17 [Alarm Override](#)
- 18 [Silent Lock and Unlock](#)
- 18 [User Selectable LED](#)

18 System Diagnostics

- 18 [Troubleshooting Remote Start](#)

19 Wiring Diagrams

- 19 [Door Lock Connections](#)
- 22 [Full System Connections](#)

Detailed Descriptions: Wire Harness Colors and Functions

Power Connector (6-pin High-Current Connector) [See page 22 for the full system diagram.](#)

These wires are listed in order of their placement in the harness connector.

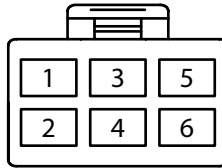

1. YELLOW – Starter Output for Remote Start (+)

The YELLOW wire supplies 12-Volt (+) to the vehicle's starter wire when remote start is enabled, and turns off once the vehicle is started.

Verification: This starter wire registers 12-Volt (+) during engine crank.

2. GREEN – Ignition 2 Output (+)

At its default setting, the GREEN wire supplies 12-Volt (+) to the vehicle's secondary ignition wire during remote start.

Verification: If present, the secondary ignition wire registers 12-Volt (+) when the vehicle is in ignition mode AND during engine crank.

Note: This wire can be programmed to perform a different function by changing its options. [Refer to Bank 3, Feature 7 on page 10.](#)

3. RED – 12-Volt Input (+)

The RED wire connects to the vehicle's primary 12-Volt (+) wire to power the system.

Verification: The power wire registers 12-Volt (+) at all times.

Note: Before making this connection, remove all module fuses until the system is completely connected.

4. RED/WHITE – 12-Volt Input (+)

The RED/WHITE wire connects to the vehicle's secondary 12-Volt (+) wire to power the remote start function.

Verification: The power wire registers 12-Volt (+) at all times.

Note: Before making this connection, remove all module fuses until the system is completely connected.

5. PURPLE – Accessory Output (+)

At its default setting, the PURPLE wire supplies 12-Volt (+) to the vehicle's accessory wire to power vehicle accessories during remote start.

Verification: The accessory wire registers 12-Volt (+) when the vehicle is running or in Accessory mode, but not during engine crank or if the vehicle is off.

Note: This wire can be programmed to perform a different function by changing its options. [Refer to Bank 3, Feature 9 on page 10.](#)

6. BLUE – Ignition 1 Input / Output (+)

The BLUE wire supplies 12-Volt (+) to the vehicle's primary ignition wire during remote start. This wire is also used to sense vehicle ignition for the Programming Functions

Verification: The primary ignition wire registers 12-Volt (+) when the vehicle is in ignition mode AND during engine crank.

Detailed Descriptions: Wire Harness Colors and Functions

Notification Connector (4-pin connector) [See page 22 for the full system diagram.](#)

These wires are listed in order of their placement in the harness connector.

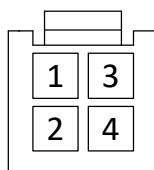

1. WHITE – Parking Light Relay Output (Internal Relay Pin 30)

At its default setting, the WHITE wire supplies 12-Volt (+) or Ground (-) to the vehicle's park light wire based on the connection of the relay input (WHITE/RED wire).

Verification: The vehicle parking light wire registers 12-Volt (+) or Ground (-) when the park lights are turned on.

2. WHITE/RED – Parking Light Relay Input (Internal Relay Pin 87)

The WHITE/RED connects to vehicle 12-Volt (+) or Ground (-) to supply the relay output (WHITE wire).

Verification for default setting:

- If the vehicle parking light wire registers 12-Volt (+) when the park lights are on, connect the WHITE/RED wire to a constant 12-Volt (+) vehicle wire.
- If the vehicle parking light wire registers Ground (-) when the park lights are on, connect the WHITE/RED wire to a reliable vehicle ground source.

3. YELLOW/BLACK – Ignition Output to Alarm (+)

The YELLOW/BLACK wire supplies 12-Volt (+) ignition output when the vehicle's ignition is set to ON, but not during the remote start runtime. This output will be used when an external alarm system is added to the vehicle.

4. BLACK – Ground Input (-)

The BLACK wire connects to a reliable vehicle ground (-) source to power the system.

Verification: The vehicle ground (-) source wire registers ground (-) at all times.

Note: Before making this connection, remove all module fuses until the system is completely connected.

Detailed Descriptions: Wire Harness Colors and Functions

Input / Output Connector (14-pin connector) [See page 22 for the full system diagram.](#)

These wires are listed in order of their placement in the harness connector.

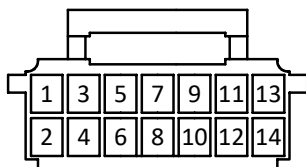

1. BLACK/WHITE – Horn Output (-)

The BLACK/WHITE wire connects to the vehicle's horn wire and supplies Ground (-) when activated from the system.

Verification: The vehicle horn wire registers Ground (-) when the horn is activated.

2. Empty

The Lock function is not supported on this model.

3. GRAY/BLACK – Hood Input (-)

The GRAY/BLACK wire connects to the vehicle's hood switch, or an installed switch that registers Ground (-) when triggered.

Verification: The vehicle hood switch wire registers Ground (-) when the hood is opened.

4. GREEN – Door Unlock (-)

The GREEN wire supplies Ground (-) when the Unlock function is activated from the remote control or system.

Verification: The vehicle lock wire registers 12-Volt (+) or Ground (-) when the Unlock button is activated. Additional parts may be required. [See Page 19 for common door lock wire diagrams.](#)

5. LIGHT BLUE – Remote Start Status Output (-)

The LIGHT BLUE wire supplies Ground (-) as soon as the remote starter is activated and remains active until 4 seconds after remote start run time has ended. This wire is most commonly used to activate data integration modules.

6. DARK BLUE/BLACK -- External Start Input (-)

The DARK BLUE/BLACK wire connects to a device or switch that, when triggered, supplies a Ground (-) output. If the vehicle ignition is off, this input will activate the remote start function.

7. BLACK/LIGHT GREEN – Factory Arm Output (-)

At its default setting, the BLACK/GREEN wire supplies a Ground (-) pulse when the system is armed and when the vehicle has been successfully started using remote start. It is typically used to re-lock vehicle doors after remote start if necessary.

Note: This wire can be programmed to perform a different function by changing its options. [Refer to Bank 3, Feature 21 on page 10.](#)

8. BROWN/BLACK – Brake Input (+)

The BROWN/BLACK wire connects to the vehicle's brake wire to supply brake status for remote start.

Verification: The vehicle brake wire registers 12-Volts (+) when the brake is activated.

9. BLACK/BLUE – Factory Disarm Output (-)

The BLACK/BLUE wire supplies a Ground (-) pulse when the system is disarmed and when remote start is activated.

Verification: In most vehicles the vehicle factory disarm wire registers Ground (-) if the driver door key cylinder is turned to the unlock position.

Note: This wire can be programmed to perform a different function by changing its options. [Refer to Bank 3, Feature 19 on page 10.](#)

Detailed Descriptions: Wire Harness Colors and Functions

Input / Output Connector (14-pin connector) (Cont.) [See page 22 for the full system diagram.](#)

These wires are listed in order of their placement in the harness connector.

10. Empty

The Trunk Release function is not supported on this model.

11. BLACK/RED – Pulse After Shutdown Output (-)

At its default setting, the BLACK/RED wire supplies a Ground (-) pulse when the remote start system is shut down. It is typically used to re-lock vehicle doors after remote start shutdown, or pulse the vehicle's door trigger to turn off accessories after vehicle shutdown.

Note: This wire can be programmed to perform a different function by changing its options. [Refer to Bank 3, Feature 22 on page 10.](#)

12. GREEN/YELLOW – Diesel Glow Plug Input (+)

The GREEN/YELLOW wire connect to the vehicle's Diesel Glow Plug detection wire.

Verification: This wire will register as 12-Volt (+) while the Diesel Wait to Start Light is illuminated.

13. BLACK/YELLOW – Pulse During Crank Output (-)

At its default setting, the BLACK/YELLOW wire supplies a Ground (-) pulse when the engine cranks during remote start.

Note: This wire can be programmed to perform a different function by changing its options. [Refer to Bank 3, Feature 20 on page 10.](#)

14. GREEN/ORANGE – Tach Input

The GREEN/ORANGE wire connects to the vehicle's tach wire at the negative side of the ignition coil or fuel injector to control engine crank during remote start.

Verification:

- Using a voltmeter set to AC volts, connect the voltmeter's positive lead to a constant vehicle 12-Volts (+) source and the negative lead to the wire to be tested.
- Start the engine and have a partner slowly press the gas pedal while the transmission is in Park. If the voltage increases as the RPM increases, this is the proper tach wire.

Detailed Descriptions: External Components

RF Antenna / LED / Programming Port

The long-range antenna kit (included) plugs into a 6-pin connector on the Pursuit module.

1. Mount the supplied antenna/receiver to a clear spot on the vehicle's windshield that will not block the driver's vision. A suitable location is high on the windshield near the rear-view mirror.
2. Be careful not to mount the antenna/receiver on any metallic window film, as this will affect system range.
3. Route the antenna/receiver cable to the Pursuit module, ensuring it does not block or interfere with deployment of the airbag (if equipped.) Plug into the antenna port.

Data Bus Interface (DBI) Port

The 4-pin Data Bus Interface enables a FlashLogic door lock or transponder interface to connect to and communicate with the vehicle data bus. The combined system saves installation time as many features that normally require individual connection can be accessed and controlled through the data bus. Please refer to the D2D (Data to Data) function list available per vehicle at www.FlashLogic.com.

Telematics Interface / Weblink Programming Port

The 4-pin Telematics port enables a connected interface such as CarLink to expand system control to a smartphone or tablet. The following features may be able to be activated from a connected device:

- Door Lock Control
- Remote Start
- Trunk Release
- Auxiliary Output*
- Sliding Doors*

Weblink Programming

This port can also be used to connect your FlashLogic Weblink for feature programming and software updating. Once connected please visit www.flashlogic.com.

* Must be supported by FLCAN

Detailed Descriptions: Setup Options

Bank 1: Add / Remove Remote Controls [See page 15 for Programming Instruction.](#)

Remote programming is located in Feature Bank 1. This system will Auto Program basic functions of the remote with one (1) button press. Basic functions are channels 1-3, Lock, Unlock, and Trunk / Start.

Feature Bank 1	Description
1	Auto Program / Start
	Press Start button on remote

To Auto Program a remote control:

1. Turn the ignition key to ON.
2. Press and release the valet button three (3) times.
3. The system will beep one (1) time, indicating you have accessed Bank 1, Remote Programming.
4. Press the Start button of each remote control you wish to program. (All channels of the remote control will be programmed.) The system will beep one (1) time when each remote control is added.
5. Turn the ignition key to OFF to exit programming mode, or cycle the ignition key OFF/ON to advance to the next Feature Bank.

To delete a remote control:

This system will store a **maximum of four (4) remote controls** in the memory. Additional programmed remote controls will delete the oldest-programmed remote control.

Deleting All Remotes:

1. Perform steps 1-3 above.
2. Press and hold the Valet button for five (5) seconds.
3. The system will sound one (1) long beep. This indicates all remotes have been deleted from memory.

Notes:

- The system will store in the memory a **maximum of four (4) remote controls**. Additional programmed remote controls will delete the oldest-programmed remote control.
- During normal operation, the **Programmed Transmitter Notification (PTN) function** indicates how many remote controls are programmed by flashing the LED a certain number of times when the vehicle ignition is turned on.

Detailed Descriptions: Setup Options

Keyless Control (Bank 2) [See page 15 for Programming Instruction.](#)

Feature Bank 2		Options					
		1 Chirp	2 Chirp	3 Chirp	4 Chirp	5 Chirp	6 Chirp
Features	1 Lock / Unlock Function	500ms	3.5sec	500ms L, DBL UL	DBL L, 500ms UL	DBL L, DBL UL	500ms L, 350ms UL
	2 Accessory Lock	NA					
	3 Accessory Unlock	NA					
	4 Exterior Illumination	NA					
	5 Auto Relock	NA					
	6 Auto Arming	NA					
	7 Notification Sound	NA					
	8 Horn Timing	16ms	30ms	40ms	50ms	10ms	
	9 Valet Override Method	NA					
	10 Driver Priority Unlock	NA					
	11 Silent Choice	NA					
	12 Park Light / Trunk Swap	NA					
	13 AUX Ch. 4	NA					
	14 AUX Ch. 5	NA					
	15 AUX Ch. 6	NA					
	16 AUX Ch. 7	NA					
	17 Security Profile	OFF	OEM Security	W/ OEM Remote Start	OFF W/ Keyless		
	18 Data Port Protocol	ADS	DBI				

Feature 1: Lock / Unlock Function

Function: **Set the lock / unlock output timing and functionality for specific vehicle lock types.**

Setting Choices:

- **Option 1** - Lock and Unlock outputs will pulse for **500 milliseconds**.
- **Option 2** - Lock and Unlock outputs will pulse for **3.5 seconds**.
- **Option 3** - **Lock** output will pulse for **500ms** ; **Unlock** output will pulse twice, **500ms each**.
- **Option 4** - **Lock** output will **pulse twice, 500ms each** ; **Unlock** output will pulse for **500ms**.
- **Option 5** - Lock and Unlock outputs will **pulse twice for 500ms**.
- **Option 6** - **Lock** output will pulse for **500ms** ; **Unlock** output will pulse for **350ms**.

Feature 2: Accessory-Activated Lock

This Feature is not available on this model.

Feature 3: Accessory-Activated Unlock

This Feature is not available on this model.

Feature 4: Exterior Illumination

This Feature is not available on this model.

Feature 5: Auto ReLock Setting

This Feature is not available on this model.

Feature 6: Automatic Arming

This feature is not available on this model.

Feature 7: Notification Sounds

This feature is not available on this model.

Detailed Descriptions: Setup Options

Keyless Control (Bank 2) (cont.) [See page 15 for Programming Instruction.](#)

Feature 8: Horn Output Duration

Function: **Set the horn output to activate for a set time.**

Setting Choices:

- **Option 1** - Output pulses for **16 milliseconds.**
- **Option 2** - Output pulses for **30 milliseconds.**
- **Option 3** - Output pulses for **40 milliseconds.**
- **Option 4** - Output pulses for **50 milliseconds.**
- **Option 5** - Output pulses for **10 milliseconds.**

Feature 9: Override Method

This feature is not available on this model.

Feature 10: Driver Priority Unlock

This Feature is not available on this model.

Feature 11: Silent Choice™

This Feature is not available on this model.

Feature 12: Park Light / Trunk Relay Function

This Feature is not available on this model.

Feature 13 - 19: AUX Ch. 4 Output

This Feature is not available on this model.

Feature 14 - 19: AUX Ch. 5 Output

This Feature is not available on this model.

Feature 15 - 19: AUX Ch. 6 Output

This Feature is not available on this model.

Feature 16 - 19: AUX Ch. 7 Output

This Feature is not available on this model.

Feature 17: Security Profile

Function: **Set the system to function as a keyless entry / convenience system or full-featured alarm / convenience system.** [See page 14 remote operation.](#)

Setting Choices:

- **Option 1** - **OFF**, no security protection.
- **Option 2** - **OEM Security**, entry zone protection.
- **Option 3** - **w/ OEM Remote Start**, entry zone protection with OEM remote start compatibility.
- **Option 4** - **OFF W/ Keyless Entry**, Keyless entry with security zone protection OFF.

Feature 18: Data Bus (DBI) Port Protocol

Function: **Set functionality of the data bus connector to accept integration modules of differing protocols.**

Setting Choices:

- **Option 1** - The data bus connector will be configured to work with modules that use the **ADS Protocol.**
- **Option 2** - The data bus connector will be configured to work with modules that use the **DBI Protocol.**

Detailed Descriptions: Setup Options

Remote Start Control (Bank 3) [See page 15 for Programming Instruction.](#)

Feature Bank 3		Options					
		1 Chirp	2 Chirp	3 Chirp	4 chirp	5 Chirp	6 Chirp
Features	1 Defrost Output	<i>NA</i>					
	2 RS Start Notification	<i>ON</i>	OFF				
	3 RS Runtime	<i>15min</i>	20min	45min	60min	5min	10min
	4 RS Parking Lights	<i>Steady</i>	Flashing				
	5 Engine Confirmation	<i>Tach</i>	Voltage	Data	Hybrid		
	6 Voltage Level	<i>>0.5v B4 Start</i>	<0.5v B4 Start				
	7 Ignition 2 Output	<i>Ignition</i>	Accessory	Start			
	8 Ignition 3 Output	<i>N/A</i>					
	9 Accessory Output	<i>Accessory</i>	Ignition	Start			
	10 Transmission	<i>NA</i>					
	11 Max Crank Time	<i>0.8sec</i>	1.0sec	1.5sec	2.0sec	3.0sec	4.0sec
	12 Diesel Delay	<i>OFF</i>	Diesel 5	Diesel 10	Diesel 15	Diesel 20	Diesel 30
	13 Temperature Start	<i>NA</i>					
	14 Crank Duration	<i>Averaging</i>	Preset				
	15 RS Shock Override	<i>NA</i>					
	16 Turbo Timer	<i>NA</i>					
	17 Start Activation	<i>Two Press</i>	One Press	Three Press			
	18 RS Lock Function	<i>No Change</i>	UL Before L After	UL Before Start	Lock After Start		
	19 Factory Disarm Output	<i>Single Pulse</i>	350ms	500ms	800ms	Door Lock Timing	
	20 Pulse During Crank	<i>During Crank</i>	GWR	Ignition	Accessory		
	21 Factory Arm Output	<i>After Start</i>	GWR	Ignition	Accessory	Start	
	22 Pulse After Shutdown	<i>After Shutdown</i>	GWR	Ignition	Accessory	Start	
	23 Additional Unlock Pulse	<i>NA</i>					

Feature 1: Defrost Output Duration

This Feature is not available on this model.

Feature 2: Remote Start Notification

Function: **Set remote start activation confirmation beeps on or off.**

Setting Choices:

- **Option 1** - On - System emits an **audible beep** when remote start is activated.
- **Option 2** - OFF -System **remains silent** when remote start is activated.

Feature 3: Remote Start Run Time

Function: **Set the maximum remote start run time if the vehicle is not entered after activation.**

Setting Choices:

- **Option 1** - Engine will run for **15 minutes**.
- **Option 2** - Engine will run for **20 minutes**.
- **Option 3** - Engine will run for **45 minutes**.
- **Option 4** - Engine will run for **60 minutes**.
- **Option 5** - Engine will run for **5 minutes**.
- **Option 6** - Engine will run for **10 minutes**.

Feature 4: Remote Start Parking Light Duration

Function: **Set parking light output to turn on or flash lights during remote start.**

Setting Choices:

- **Option 1** - Lights **remain on** during remote start.
- **Option 2** - Lights **flash** during remote start.

Detailed Descriptions: Setup Options

Remote Start Control (Bank 3) (cont.) [See page 15 for Programming Instruction.](#)

Feature 5: Engine Confirmation

Function: **Determine how the system knows if remote start was successful.**

Setting Choices:

- **Option 1** - Determined by **measurement** from the **Purple/White** Tach Input wire.
- **Option 2** - Determined by the **voltage difference** before remote start and after as set in **Bank 3, Feature 6**.
- **Option 3** - Receives information through an attached **data bus interface**.
- **Option 4 - No sensing**; assumes vehicle has started based on setting in **Bank 3, Features 11 & 14**.

Feature 6: Start Sensing Voltage Level

Function: **Set the sensitivity of voltage variance measurement to determine if the vehicle has started when Feature 5 is set to option 2, Voltage.**

Setting Choices:

- **Option 1 - High**: Voltage difference before remote start and after must be greater than .5 volts.
- **Option 2 - Low**: Voltage difference before remote start and after must be less than .5 volts.

Feature 7: Ignition 2 Output Function (Green)

Function: **Set the functionality of the programmable Ignition 2 output.**

Setting Choices:

- **Option 1** - Wire sends 12-Volt (+) during ignition **and start**.
- **Option 2** - Wire sends 12-Volt (+) during ignition; **drops out during start**.
- **Option 3** - Wire sends 12-Volt (+) during start **only**.

Feature 8: Ignition 3 Output Function (Pink)

This Feature is not available on this model.

Feature 9: Accessory Output Function (Purple)

Function: **Set the functionality of the programmable Accessory output.**

Setting Choices:

- **Option 1** - Wire sends 12-Volt (+) during ignition; **drops out during start**.
- **Option 2** - Wire sends 12-Volt (+) during ignition **and start**.
- **Option 3** - Wire sends 12-Volt (+) during start **only**.

Feature 10: Transmission Type

This Feature is not available on this model.

Feature 11: Maximum Crank Time

Function: **Set maximum crank time for all remote start settings.**

Setting Choices:

- **Option 1** - Starter will crank for **.8 seconds**.
- **Option 2** - Starter will crank for **1 second**.
- **Option 3** - Starter will crank for **1.5 seconds**.
- **Option 4** - Starter will crank for **2 seconds**.
- **Option 5** - Starter will crank for **4 seconds**.

Detailed Descriptions: Setup Options

Remote Start Control (Bank 3) (cont.) [See page 15 for Programming Instruction.](#)

Feature 12: Diesel (Pre-Start) Delay

Function: **After remote start ignition is activated, set delay of crank to accommodate diesel engines.**

Setting Choices:

- **Option 1** - Vehicle starts **immediately** after remote start ignition.
- **Option 2** - Start is delayed for **5 seconds** after remote start ignition.
- **Option 3** - Start is delayed for **10 seconds** after remote start ignition.
- **Option 4** - Start is delayed for **15 seconds** after remote start ignition.
- **Option 5** - Start is delayed for **20 seconds** after remote start ignition.
- **Option 6** - Start is delayed for **45 seconds** after remote start ignition.

Feature 13: Temperature-Based Start Setting

This Feature is not available on this model.

Feature 14: Crank Duration

Function: **Set how the system will determine how long to crank the starter.**

Setting Choices:

- **Option 1** - Starter will crank based on **average of last 8 times** the vehicle was started with the key.
- **Option 2** - Starter will crank for **maximum time** as set in **Bank 3, Feature 11.**

Feature 15: Shock Sensor Control

This feature is not available on this model.

Feature 16: Turbo Timer Setting

This Feature is not available on this model.

Feature 17: Remote Start Activation

Function: **Set remote start to activate with one, two, or three presses from the remote control or pulses detected on the Dark Blue/Black External Activation Input.**

Setting Choices:

- **Option 1** - Press the Start button **2 times** for remote start.
- **Option 2** - Press the Start button **1 time** for remote start.
- **Option 2** - Press the Start button **3 times** for remote start.

Feature 18: Remote Start Lock Control (Data Only)

Function: **If desired, set door lock outputs to function before or after remote start.**

Setting Choices:

- **Option 1** - Remote Start Lock Control is **inactive**.
- **Option 2** - Doors will **unlock before remote start; lock after remote start.**
- **Option 3** - Doors will **unlock before remote start.**
- **Option 4** - Doors will **lock after remote start.**

Feature 19: Factory Disarm Output Function (BLACK/BLUE)

Function: **Set the functionality of the programmable output.**

Setting Choices:

- **Option 1** - Sends a **1-second pulse** before start and during Unlock.
- **Option 2** - Sends a **350ms pulse** before start and during Unlock.
- **Option 3** - Sends a **500ms pulse** before start and during Unlock.
- **Option 4** - Sends a **800ms pulse** before start and during Unlock.
- **Option 5** - Sends a pulse **before start and during unlock** based on setting of **Bank 2, Feature 1.**

Detailed Descriptions: Setup Options

Remote Start Control (Bank 3) (Cont.) [See page 15 for Programming Instruction.](#)

Feature 20: Pulse During Crank Output Function (BLACK/YELLOW)

Function: **Set the functionality of the programmable output.**

Setting Choices:

- **Option 1** - Pulse During Crank.
- **Option 2** - GWR, Remote Start Status Output.
- **Option 3** - Ignition Timing.
- **Option 4** - Accessory Timing.

Feature 21: Factory Arm Output Function (BLACK/LIGHT GREEN)

Function: **Set the functionality of the programmable output.**

Setting Choices:

- **Option 1** - Pulse After Start Output.
- **Option 2** - GWR, Remote Start Status Output.
- **Option 3** - Ignition Output.
- **Option 4** - Accessory Output.
- **Option 5** - Start Output.

Feature 22: Pulse After Shutdown Output Function (BLACK/RED)

Function: **Set the functionality of the programmable output.**

Setting Choices:

- **Option 1** - Pulse After Shutdown Output.
- **Option 2** - GWR, Remote Start Status Output.
- **Option 3** - Ignition Output.
- **Option 4** - Accessory Output.
- **Option 5** - Start Output.

Feature 23: Additional Unlock Pulses

This Feature is not available on this model.

Detailed Descriptions: System Operation

Remote Control Operation

This system includes two (2) remote controls. The matrix below describes the basic functions of each remote. See Owners Guide for complete remote operation instruction.

One Button Remotes (1-Way) - Standard Configuration



Button	Action	Function
	Press 1x	No Function
	Press 2x	Start
	Hold 3 Seconds	Panic (Engine OFF) Unlock (Engine ON)

One Button Remotes (1-Way) - Security/Keyless Configuration



Button	Action	Function
	Press 1x	Lock
	Press 2x	Unlock
	Hold 3 Seconds	Start

Quick Reference: System Programming

Programming Mode Entry and Exit Procedure

Once the system is installed and powered up, you will use the vehicle ignition, valet button and a programmed remote control to set all system options. Feature options are divided into categories, or **Banks**, as described throughout this section. **Ensure that at least one remote control is programmed** to the system. If not, or if you need to program more remote controls, use the diagram steps to access **Bank 1**.

The siren and LED will indicate your status and selections. Follow the diagram below to enter and maneuver through the programming procedure.

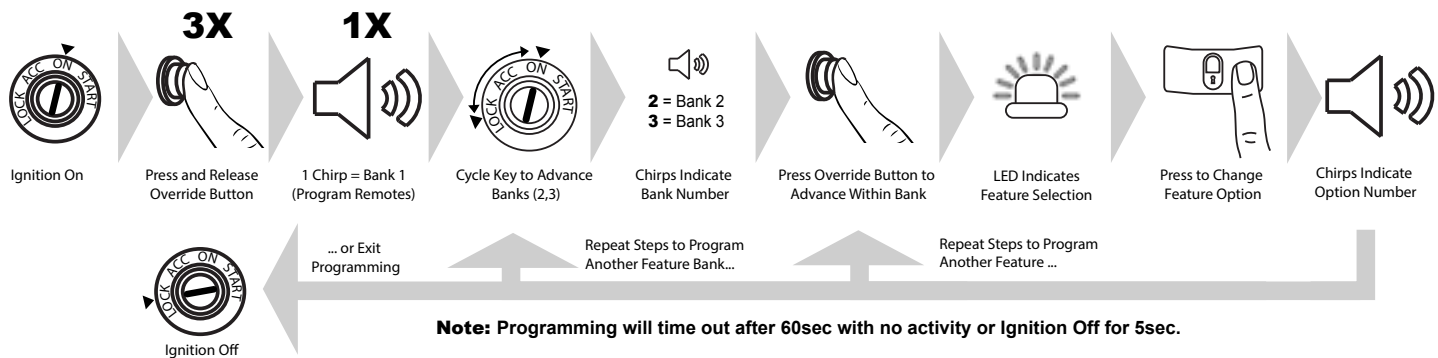

1. Turn the ignition ON.
2. Press and release the valet button three (3) times.
3. The system will beep (1) one time, indicating you have accessed Bank 1.
4. Each cycle of the Ignition, OFF/ON, will advance to the next bank (up to Bank 3) then restart at Bank 2. (Note: To re-access Bank 1 for Remote Control programming, you will need to exit and re-enter programming mode.)
5. The system will beep a number of times to indicate the Bank number:
 - 1 beeps: **Bank 1** - [Programming Remote Controls](#)
 - 2 beeps: **Bank 2** - [Keyless Control Options](#)
 - 3 beeps: **Bank 3** - [Remote Start Control Options](#)
6. Once you have accessed the desired bank, press the valet button to advance through the features. The LED will flash a number of times to indicate the feature, based on the charts that follow this section. The system will chirp a number of times to indicate the Option programmed.
7. Once you have accessed the desired feature, press the Start button on the remote control to advance through the feature's setting options. The system will beep a number of times to indicate the Option setting, based on the charts that follow this section.
8. Once you have made the desired setting, you can press the valet button to advance through the features within the bank, or cycle the Ignition key OFF/ON to advance to the next bank.
9. Once you have completed programming, **you MUST turn the ignition key to OFF** to exit the programming mode. Programming will automatically exit after 60 seconds of inactivity.

Quick Reference: System Programming

Bank 1: Remote Control Programming Options [See page 7 for a detailed description.](#)

Feature Bank 1		Description
1	Auto Program / Start	Press Start button on remote

Bank 2: Keyless Options [See pages 8-9 for detailed descriptions.](#)

Feature Bank 2		Options					
		1 Chirp	2 Chirp	3 Chirp	4 Chirp	5 Chirp	6 Chirp
Features	1 Lock / Unlock Function	500ms	3.5sec	500ms L, DBL UL	DBL L, 500ms UL	DBL L, DBL UL	500ms L, 350ms UL
	2 Accessory Lock	NA					
	3 Accessory Unlock	NA					
	4 Exterior Illumination	NA					
	5 Auto Relock	NA					
	6 Auto Arming	NA					
	7 Notification Sound	NA					
	8 Horn Timing	16ms	30ms	40ms	50ms	10ms	
	9 Valet Override Method	NA					
	10 Driver Priority Unlock	NA					
	11 Silent Choice	NA					
	12 Park Light / Trunk Swap	NA					
	13 AUX Ch. 4	NA					
	14 AUX Ch. 5	NA					
	15 AUX Ch. 6	NA					
	16 AUX Ch. 7	NA					
	17 Security Profile	OFF	OEM Security	W/ OEM Remote Start	OFF W/ Keyless		
	18 Data Port Protocol	ADS	DBI				

Bank 3: Remote Start Options [See pages 10-13 for detailed descriptions.](#)

Feature Bank 3		Options					
		1 Chirp	2 Chirp	3 Chirp	4 chirp	5 Chirp	6 Chirp
Features	1 Defrost Output	NA					
	2 RS Start Notification	ON	OFF				
	3 RS Runtime	15min	20min	45min	60min	5min	10min
	4 RS Parking Lights	Steady	Flashing				
	5 Engine Confirmation	Tach	Voltage	Data	Hybrid		
	6 Voltage Level	>0.5v B4 Start	<0.5v B4 Start				
	7 Ignition 2 Output	Ignition	Accessory	Start			
	8 Ignition 3 Output	N/A					
	9 Accessory Output	Accessory	Ignition	Start			
	10 Transmission	NA					
	11 Max Crank Time	0.8sec	1.0sec	1.5sec	2.0sec	3.0sec	4.0sec
	12 Diesel Delay	OFF	Diesel 5	Diesel 10	Diesel 15	Diesel 20	Diesel 30
	13 Temperature Start	NA					
	14 Crank Duration	Averaging	Preset				
	15 RS Shock Override	NA					
	16 Turbo Timer	NA					
	17 Start Activation	Two Press	One Press	Three Press			
	18 RS Lock Function	No Change	UL Before L After	UL Before Start	Lock After Start		
	19 Factory Disarm Output	Single Pulse	350ms	500ms	800ms	Door Lock Timing	
	20 Pulse During Crank	During Crank	GWR	Ignition	Accessory		
	21 Factory Arm Output	After Start	GWR	Ignition	Accessory	Start	
	22 Pulse After Shutdown	After Shutdown	GWR	Ignition	Accessory	Start	
	23 Additional Unlock Pulse	NA					

Quick Reference: System Programming & Diagnostics

Data Port Protocol Selection

The default data port protocol of this model is ADS (iDatalink 2-Way). This model is capable of detecting the correct data port protocol (ADS or DBI) and automatically configuring Feature Bank 2; Feature 18. To initialize the detection procedure:

1. Press and hold the valet button.
2. Cycle the vehicle's Ignition ON/OFF two (2) times.
3. Release the valet button.

Note: This feature is only available on module firmware v2.00 or higher.

Tach Function

When using the GREEN/ORANGE tach wire, the vehicle tach rate must be programmed.

Programming with valet button when tach wire is connected:

1. Turn the ignition key to the ON position.
2. Press and release the valet button three (3) times.
3. Immediately turn the ignition key OFF.
4. Press and hold the valet button, then start the vehicle using the key.
5. When the unit senses the tach signal, the parking lights will begin to flash.
6. Allow the vehicle to settle to a normal idle speed.
7. Release the valet push-button switch.

The parking lights will turn on for two (2) seconds and one (1) long chip will indicate that the learned tach signal is stored and the unit has exited tach learn mode.

Programming without valet button when tach wire is connected:

1. Turn the ignition key to the ON position and start the vehicle's engine.
2. Wait for Engine RPM to lower to a normal idle.
3. Press and hold the vehicle's brake pedal.
4. Press the LOCK button on the OEM remote or the Carlink App.

The vehicle's parking lights will flash seven (7) times to indicate the tach signal has been learned. If the parking lights do not flash, locate another tach source and repeat steps 1 - 4 above.

Note: Programming tach signal via OEM or Telematics control is only available on Firmware v1.47 or Higher.

Valet Alarm Override (Optional)

The Valet Override procedure will disable the alarm when the remote is not available or has become inoperative. If the vehicle door is opened without disarming, the alarm will sound and the vehicle will not start when attempting to start with the key. To disable the alarm:

1. Turn the vehicle ignition to ON.
2. Within five (5) seconds, press and release valet button on antenna one (1) times

The alarm will silence and the vehicle will now start normally with the key.

Quick Reference: System Programming & Diagnostics

Silent Lock and Unlock (Security/Keyless Mode Only)

Program the Pursuit system to Lock and Unlock without notification beeps.

1. Turn the ignition ON then OFF.
2. Press and release the valet button three (3) times. The system will respond with one (1) beep for ON or two (2) beeps for OFF.

User Selectable LED

This feature will control whether the LED is ON or OFF when the system is Locked. This will be selectable on-the-fly without entering the programming feature banks.

1. Turn the ignition ON, OFF, ON, OFF.
2. Press and hold valet button for five (5) seconds.

The system will respond with one (1) flash for ON or two (2) flashes for OFF.

Troubleshooting Remote Start

All Pursuit remote start systems will provide parking light feedback to display remote start errors or shutdowns. The vehicle parking lights will flash to display error or shutdown code.

1	Runtime Expired
2	Remote Shutdown
3	Brake On
4	Manual Mode
5	Hood Open
6	Low / No Tach
7	Tach Programming
8	High Tach

Quick Reference: Wiring Diagrams

Door Lock Connections

Negative-Trigger Door Locks

Verification: The vehicle wires register Ground when the Lock and Unlock switches are activated.

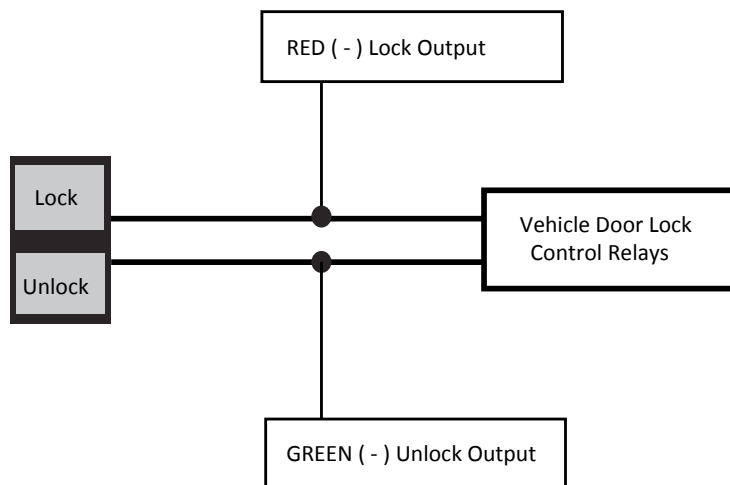

Positive-Trigger Door Locks

Verification: The vehicle wires register 12V+ when the Lock and Unlock switches are activated.

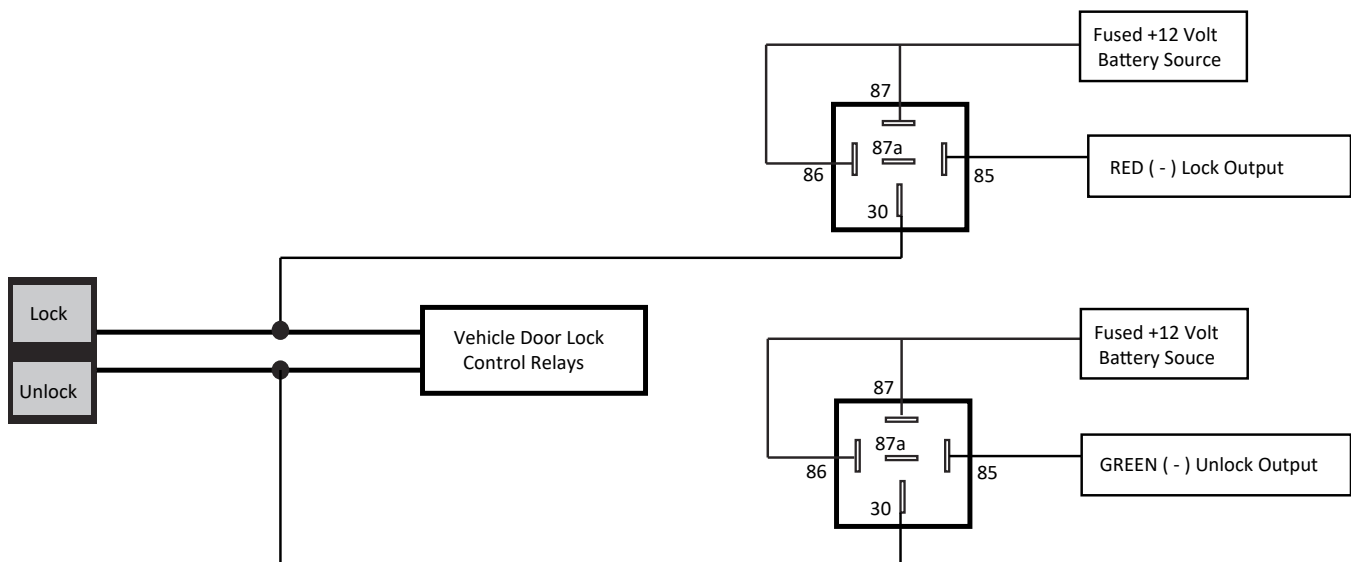

Quick Reference: Wiring Diagrams

Door Lock Connections

Single-Wire Negative Multiplex Door Locks (Relays required)

Verification: The vehicle wire registers variable Ground values when the Lock and Unlock switches are activated. Please consult the vehicle-specific wire and location chart for resistor values.

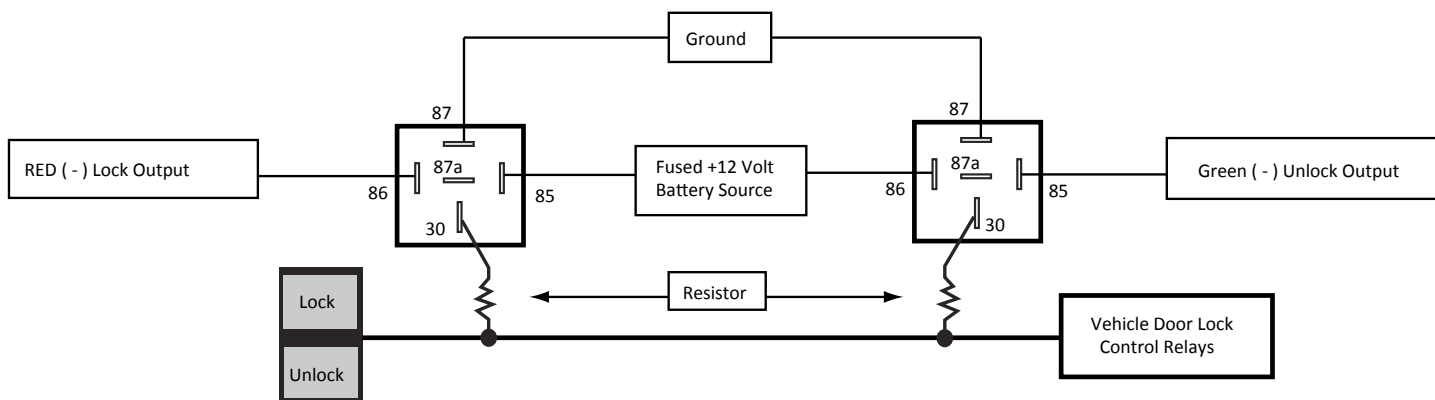

Single-Wire Positive Multiplex Door Locks (Relays required)

Verification: The vehicle wire registers variable 12V+ values when the Lock and Unlock switches are activated. Please consult the vehicle-specific wire and location chart for resistor values.

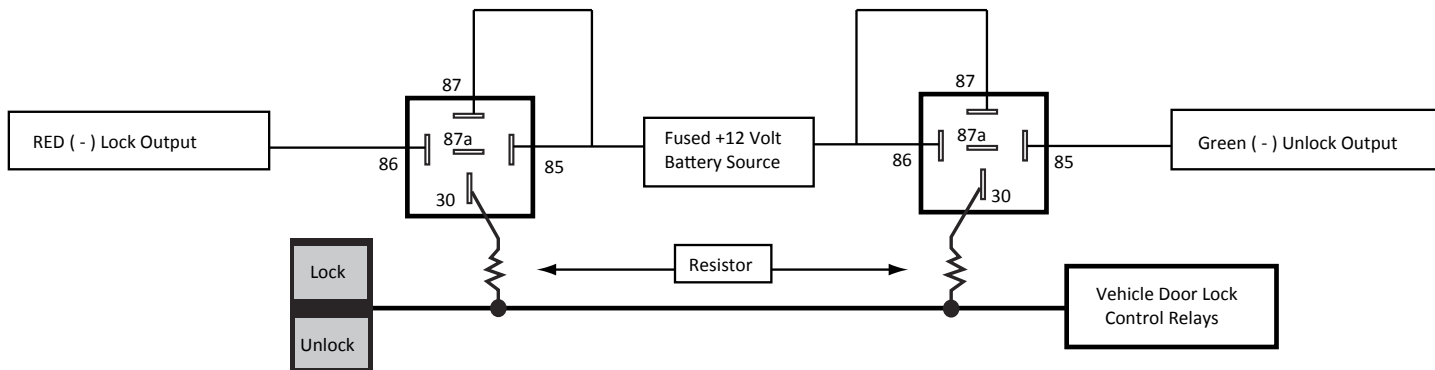

Quick Reference: Wiring Diagrams

Door Lock Connections

Reverse-Polarity Door Locks (Relays required)

Verification: The vehicle wires rest at Ground and register 12V+ when the Lock and Unlock switches are activated.

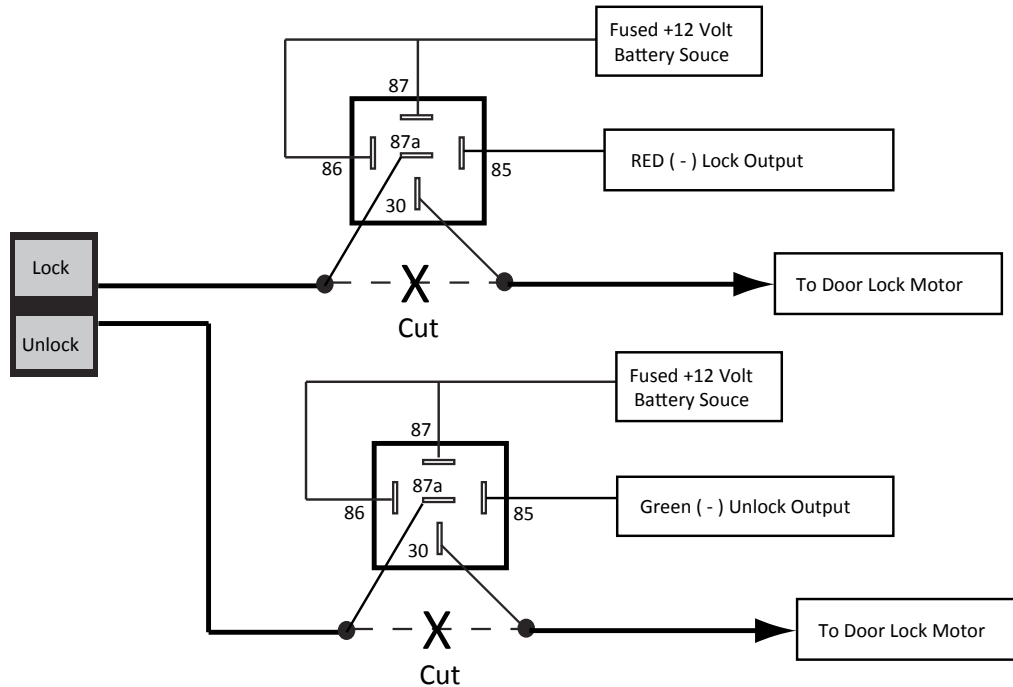

Aftermarket Actuators (Relays and door lock actuators required)

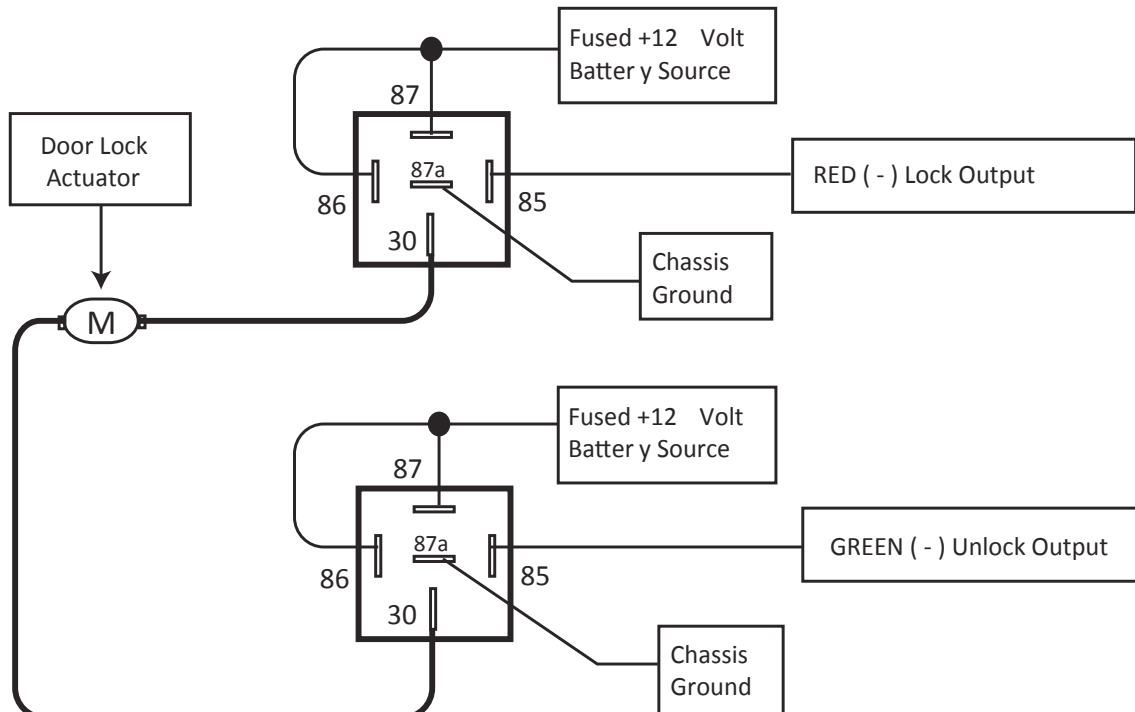

Quick Reference: Wiring Diagrams

