

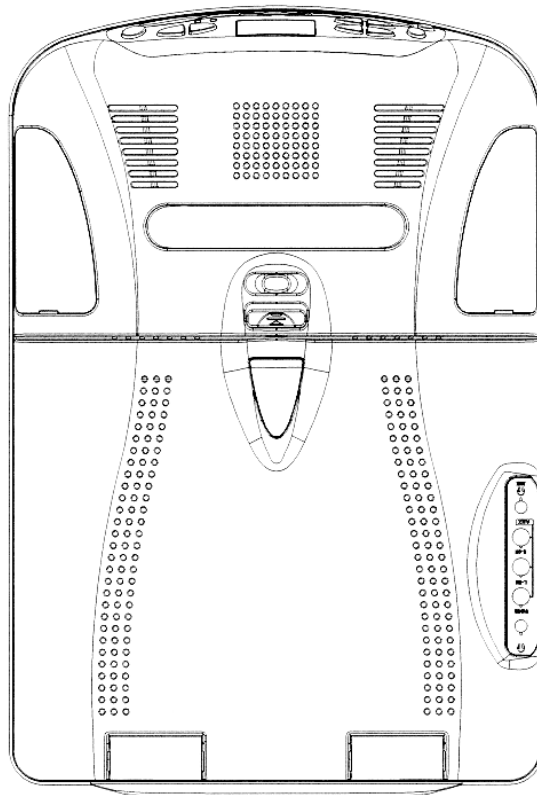

AUDIOVOX[®]
ELECTRONICS CORP.

VOD1048 Drop Down Video TV/Monitor with DVD
Revision A



Installation Guide

Notice:

An LCD panel and/or video monitor may be installed in a motor vehicle and visible to the driver if the LCD panel or video monitor is used for vehicle information, system control, rear or side observation or navigation. If the LCD panel or video monitor is used for television reception, video or DVD play, the LCD panel or video monitor must be installed so that these features will only function when the vehicle is in "park" or when the vehicle's parking brake is applied.

An LCD panel or video monitor used for television reception, video or DVD play that operates when the vehicle is in gear or when the parking brake is not applied must be installed to the rear of the driver's seat where it will not be visible, directly or indirectly, to the operator of the motor vehicle.

Licensed under one or more of the following patents,
Patent NOS. 5,775,762 and 5,927,784

MATERIALS INCLUDED IN THIS PACKAGE:

- 1) VOD1048 TV/Video Monitor with DVD (1pc)
- 2) 14 Pin Power / Signal harness (P/N112C3396) (1 pc)
- 3) 3 Wire Power Wire Harness (P/ N12B3397) (1 pc)
- 4) Trim Ring Insert (P/N102C4018) (1pc)
- 5) Hardware Package Screws (6 pcs)
- 6) Remote Control (136-3762) (1pc)

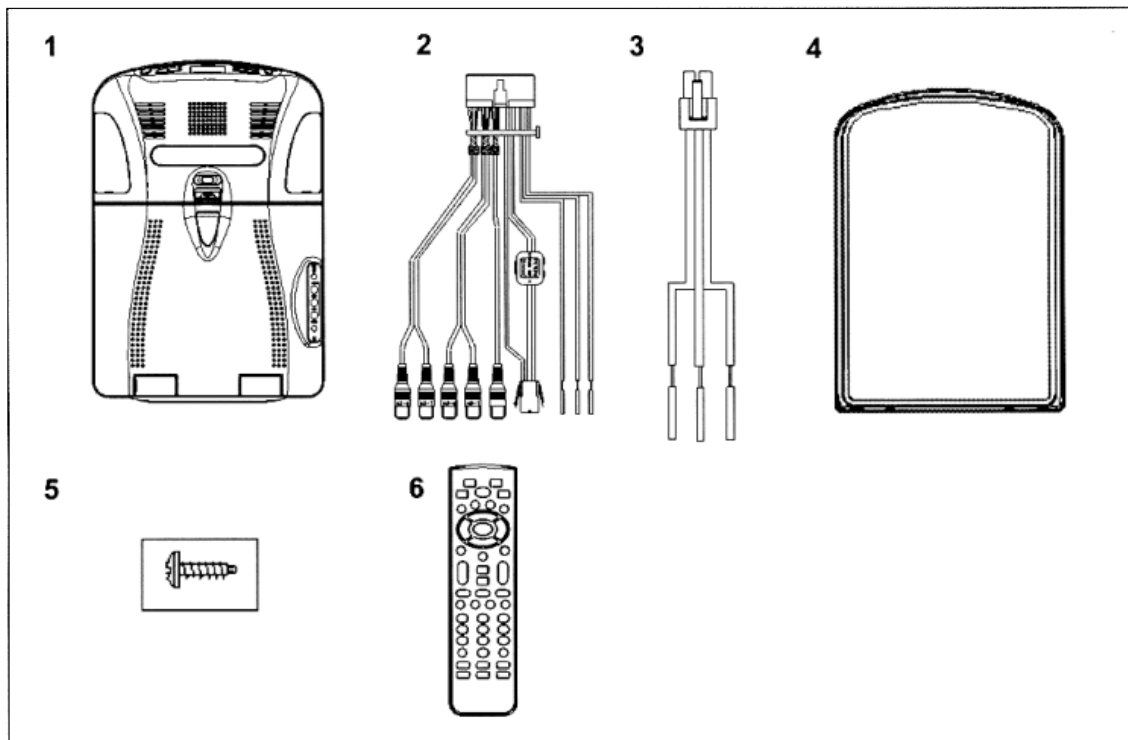

TOOLS REQUIRED:

- #2 Phillips Screwdriver
- #1 Phillips Screwdriver
- Utility or Razor Knife or Shears
- Wire Strippers
- Upholstery hook tool (for removal of panels as necessary)
- Electrical Tape
- Masking Tape
- Multimeter (to verify 12 volt DC and continuity: Do not use a test light or logic probe)
- Marker pen – to mark headliner
- Scribe (to mark trim ring if used)
- Misc. electrical connectors (to connect to vehicle power source). Requirements will vary from vehicle to vehicle)
- DVD Movie (to verify system operation after installation)

GENERAL INSTALLATION APPROACH:

- 1) Decide upon system configuration and options that will be installed (i.e.: what components, VCP, Video Game, FM Modulator external amp, wireless headphones, VCP, etc.).
- 2) Review all manuals to become familiar with electrical requirements and hook ups.
- 3) Decide upon mounting locations of all components and method of mounting.
- 4) Prep the vehicle by removing any interior trim necessary to gain access to vehicle's wiring as well as all areas where interconnecting wire harnesses will need to be located. If any access holes need to be cut into the vehicle (headliner, other trim components etc.), this should be done now as well. (Refer to Page 3).
- 5) Route the wiring harnesses throughout the vehicle as necessary. (Refer to the Wiring Diagrams on pages 6 of this manual as well as the wiring instructions for the individual components and accessory options being installed). Be sure that all wiring is protected from sharp edges and is routed in such a manner that it will not be pinched when all components and interior trim are fully installed. Be sure to leave enough slack in the wiring at each component to allow working room.
- 6) Remove all A/V system components from their packaging and place them loosely in the vehicle at their respective locations.
- 7) Connect all components together (electrically) and verify proper operation of all system functions. Note: This is best done BEFORE, components have been permanently mounted.
- 8) After verifying proper operation of the system, proceed to mount of each component.
- 9) When all components are mounted, recheck function of entire system again to ensure that no wiring was pinched or connected improperly during final installation.

GENERAL SYSTEM CONFIGURATIONS:

The following is intended to provide some of the system configurations that are possible with the VOD1048 series Drop Down Video Systems:

System 1: Video Monitor with TV tuner and built -in DVD Player (VOD1048).

System 2: Video Monitor with TV tuner and built -in DVD Player (VOD1048), and optional VCP or Video Game.

Notes :

There are a few audio output options that can be added as follows:

- a) Wired headphones can be added to a VOD1048 system.
- b) An FM Modulator can be added to a VOD1048 system using the FMM100A.
- c) Wireless Headphones (P/N IR2CHS).

The VOD1048 video system is only intended for an overhead, drop down installation. It is not intended for Seatback or any other type of mounting. The hinging mechanism is designed for horizontal, drop down use only.

VEHICLE PREPARATION:

- 1) Locate a constant power source (+12v at all times), an accessory power source (+12v when key is in the ACC. and run positions, and 0v when key is off), and also a good ground generally, these wires can be found at the ignition switch or fuse-box.
- 2) The mounting method and location will vary from vehicle to vehicle, so this manual will only focus on the installation of the video monitor and related accessories.
- 3) Generally, the best location for the video monitor is where the vehicle's factory dome light is installed. The monitor should be located in such a manner that it can be comfortably viewed by rear seat passengers. **NEVER INSTALL THE MONITOR IN A PLACE WITHIN THE DRIVER'S VIEW. THIS IS NOT ONLY DANGEROUS, BUT IT IS ALSO ILLEGAL IN MANY STATES.**
- 4) Once the mounting location of the monitor has been determined, there may be additional preparation work necessary, depending on the vehicle structure and installation method. Some of the steps that may be required are:
 - A) Removal of the vehicle's dome light
 - B) Optional vehicle specific overhead console can also be used instead of mini-console. Supplied Trim Ring Insert would be used in this situation, and Part Number 1187104PL console spacer must be purchased (follow the supplied instructions for installation detail).
 - C) If the mini-console will be used, it will have to be trimmed to fit the contour of the vehicle's headliner. Refer to the "Mini-Console installation" section in this manual.

MINI CONSOLE INSTALLATION:

This page only covers special installation considerations for the mini-console installation. If the video monitor is to be installed in a vehicle with the mini console, this console may need to be trimmed to fit the contour of the vehicle headliner.

- 1) In this installation, the video monitor is mounted directly to the overhead cross-member in the roof using the mounting screw bosses. These screw bosses should contact the cross-member directly (i.e.: no gap between the screw boss and the roof structure). Also, be sure that the screws do not pierce the outer roof skin when fully fastened to the cross-member. It is important that the screws used in this installation are not overtightened, and that the video monitor and mini-console are mounted in such a way that the assembly does not distort (or bend) when the mounting screws are tightened. An alternate method is to use a piece of plywood (9 3/4"x7"x3/4"). First secure the plywood block to the cross-member, then screw the monitor into the plywood. See the drawing on page 5.
- 2) It is best to mount the video monitor to the roof structure without the mini-console first. There should be a gap between the headliner and the outer flange of the video monitor. The mini-console should be cut to fill this gap. Apply masking tape to the outer surface of the mini-console in the areas where the cut will be made.
- 3) Mark the cut to follow the necessary contour of the roof. The suggested method of marking is as follows:
 - A) First mark the narrowest point of the mini-console on the masking tape. Be careful to consider not only vertical location, but fore-aft location.
 - B) Using the handle of a screwdriver, make a "transfer marking tool". See diagram below. Place the tool against the roof and the marker against the masking tape on the mini-console. Trace the cut to be made around the entire perimeter of the mini-console.
 - C) Cut the mini-console using a sharp utility knife or shears. Make the cut in several passes over the marked line, each time cutting a little deeper. It is not necessary to cut completely through the plastic, the cut only need be over 50% of the wall thickness of the plastic. By bending the cut back and forth several times, the plastic will break cleanly at the cut.
 - D) Check the fit of the trimmed console and make any minor adjustments necessary.
- 4) The mini-console can be painted or covered with a material that matches the headliner before assembling the mini-console to video monitor.
- 5) The finished mini-console should be attached to the video monitor, then attach the assembly to the roof.

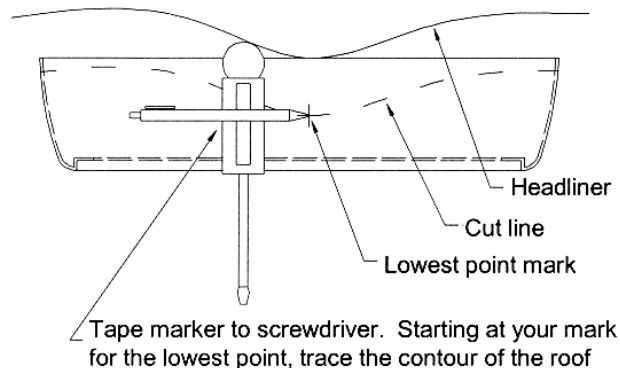

VOD1048

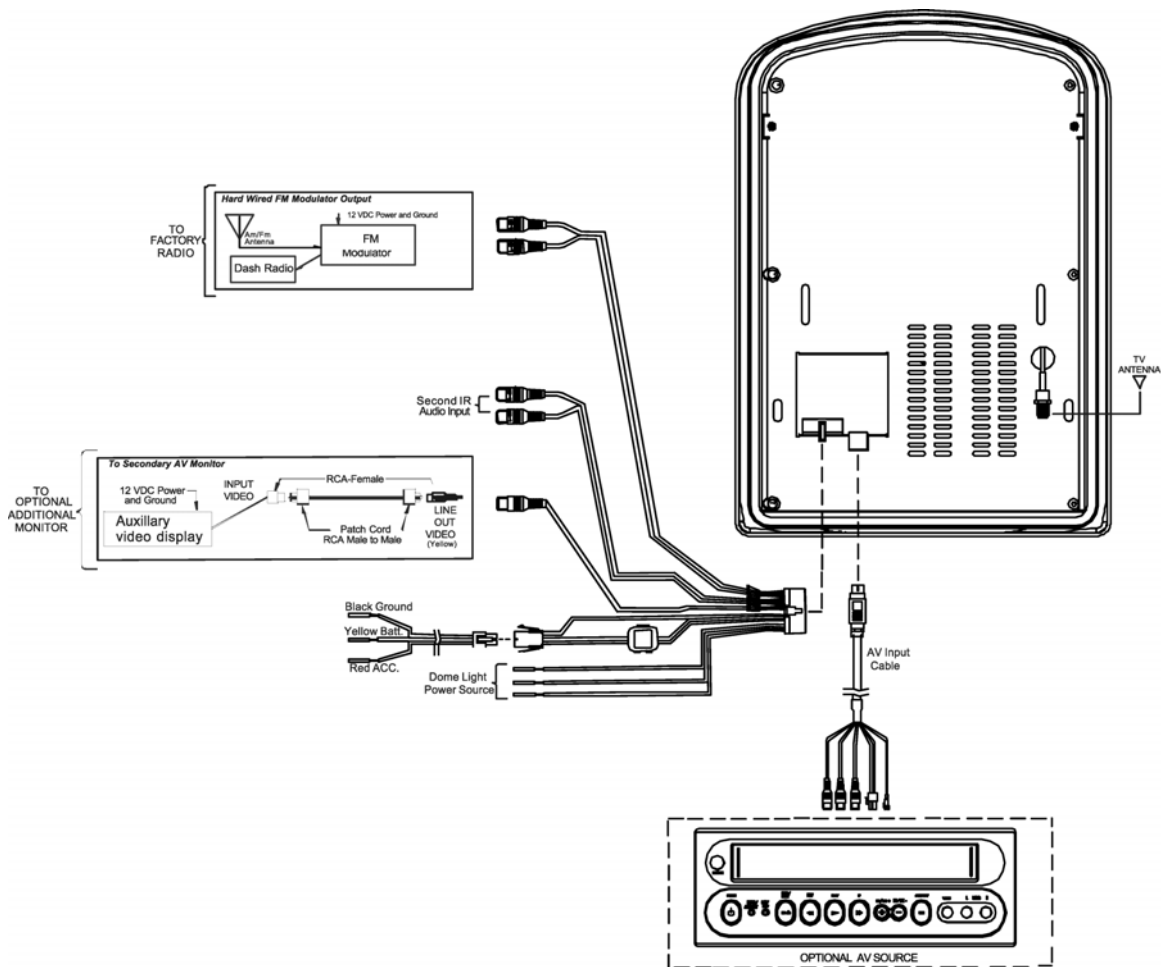

Figure A

- 1) Make the connections to the vehicle for the 14 pin wiring harness and battery wire.
- 2) Connect the 14 pin harness to the mating connector on the Video Monitor.
- 3) Connect the female right and left audio output RCA to optional FMM100A.
- 4) Connect power harness to vehicle's electrical system by tapping into an accessory hot line, a battery wire and a good ground.
- 5) Verify all functions of the System before final mounting of the finished assembly.
- 6) Mount and connect the Television antenna.

Note: A VCP or other A/V Component can be connected to the video monitor system using the 8 pin DIN cable.

CONNECTING THE DOME LIGHTS

The dome lights in the video monitor require three connections to the vehicle's wiring. There are two common types of dome light circuits used, positive or negative switched. Positive systems supply voltage to the interior lights to turn them on, negative switched systems apply ground to illuminate the bulbs. To determine which system you have you must locate the wires at the dome light. On a positive switched system, with all the doors closed and the lights out, both wires at the dome light will rest at ground. When the light is activated, one of these wires will switch to +12 vdc. This is the vehicle's switching wire. On a negative switched system, with all the doors closed and the lights out, both wires at the dome light will rest at + 12vdc. When the light is activated, one of these wires will switch to ground. This is the switching wire.

For positive systems, connect the purple / brown (Lamp auto) wire to the vehicle's switched wire. Then connect the red / black (lamp on) wire to a fused constant 12 volt source and the black / red (lamp common) wire to a good ground.

For negative systems, connect the purple / brown (Lamp auto) wire to the vehicle's switched wire. Then connect the red / black (lamp on) wire to a good ground and the black / red (lamp common) wire to fused constant 12 volt source. Negative systems are commonly found on General Motors and import vehicles.

Note:

Some vehicles which incorporate transistorized control of the dome light circuit, such as the 1999 Dodge Caravan, may require that the purple / brown (Lamp auto) wire be connected to the door pin switch wire, as the additional current draw of the Monitor's lights may not be supported by the output of the vehicles body control computer.

Positive Switched Dome lighting

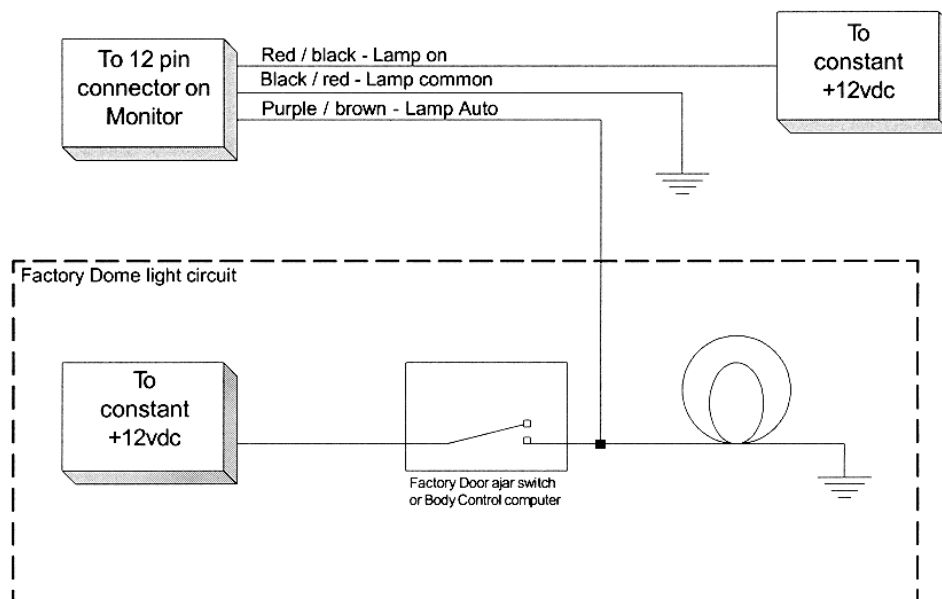

Negative Switched Dome lighting

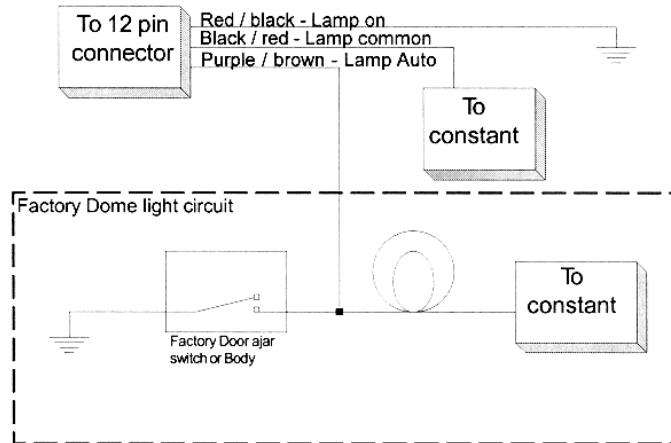

Troubleshooting:

SYMPTOM:

No power at Video Monitor

REMEDY:

-Verify +12 VDC on Red wire at 3 Wire Power Harness behind video monitor. Verify ground connection with continuity test from known good ground to black wire at 3 Wire Power Harness. Verify +12 VDC on Yellow wire at 3 Wire Power Harness behind video monitor.

Power but no video or sound

-Verify that the correct source is selected (i.e.: 1,2,3 or 4). Verify that the source is on and playing a known good media (such as a videotape). Verify connections at both ends of the source component harness.

Picture, but no sound

-Push and hold the volume up button until sound is heard over headphones. If problem is limited to the dash radio, verify radio is tuned to the correct channel, and that power to the wired RF modulator is on. (Refer to instructions with modulator kit). Otherwise, verify all connections per the wiring diagram on page 6.

Static on TV Stations (Tuner Version Only)

-Press Auto Program button. Then press Ch. UP or Ch. DOWN. Verify antenna mounting and connections to the tuner.
Note: Due to the nature of TV signals, vehicle motion, direction the vehicle is facing, distance from the transmitter, nearby surroundings and weather may adversely affect TV reception. These conditions may result in the following: picture roll, "snowy" picture, or momentary loss of color.

No Infrared remote functions for VCP (or other components)

-Check batteries in the hand held remote (not included with this kit). Verify that the IR LED (page 6 Wiring Diagram) is properly attached to the sensor window of the VCP (or other component).



For Customer Service
Visit Our Website At
www.audiovox.com
Product Information, Photos,
FAQ's Owner's Manuals

128-7068A