

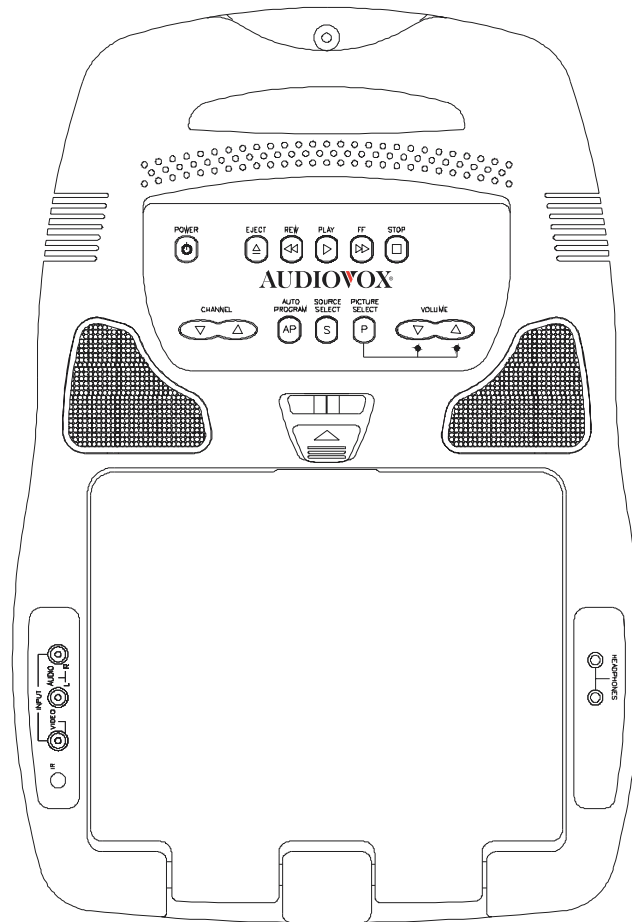

AUDIOVOX®
ELECTRONICS CORP.

VOD808 Drop Down DVD Video Monitor



Installation Guide

IMPORTANT

An LCD panel and/or video monitor may be installed in a motor vehicle and visible to the driver if the LCD panel or video monitor is used for vehicle information, system control, rear or side observation or navigation. If the LCD panel or video monitor is used for television reception, video or DVD play, the LCD panel or video monitor must be installed so that these features will only function when the vehicle is in 'park' or when the vehicle's parking brake is applied.

An LCD panel or video monitor used for television reception, video or DVD play that operates when the vehicle is in gear or when the parking brake is not applied, must be installed to the rear of the driver's seat where it will not be visible, directly or indirectly, to the operator of the motor vehicle.

MATERIALS INCLUDED IN THIS PACKAGE:

- 1) VOD808 DVD Video Monitor with TV Tuner (P/N 136D2402) (1 pc)
- 2) Accessory 8 pin FM Transmitter Harness (P/N112B3262) (1 pc)
- 3) 2 Pin Power Wire Harness with choke (P/N 112B3143) (1 pc)
- 4) 12 Pin Power / Signal Harness (P/N 112B2821) (1 pc)
- 5) Protective Covers (2pcs)
Left Protective Cover for IR sensor (P/N 102B3689) (1pc)
Right Protective Cover for Headphone Jacks (P/N 102B3690) (1pc)
- 6) Hardware Package
#4 x 3/8" Screws (12 pcs)
#8 x 5/8" Self Drilling Screws (5 pcs)
#8 x Washer (5 pcs)
Rubber Plug (1pc)
- 7) Remote Control (P/N 136B2154) (1 pc)
- 8) FM Modulator (P/N 136C2404) (1pc)

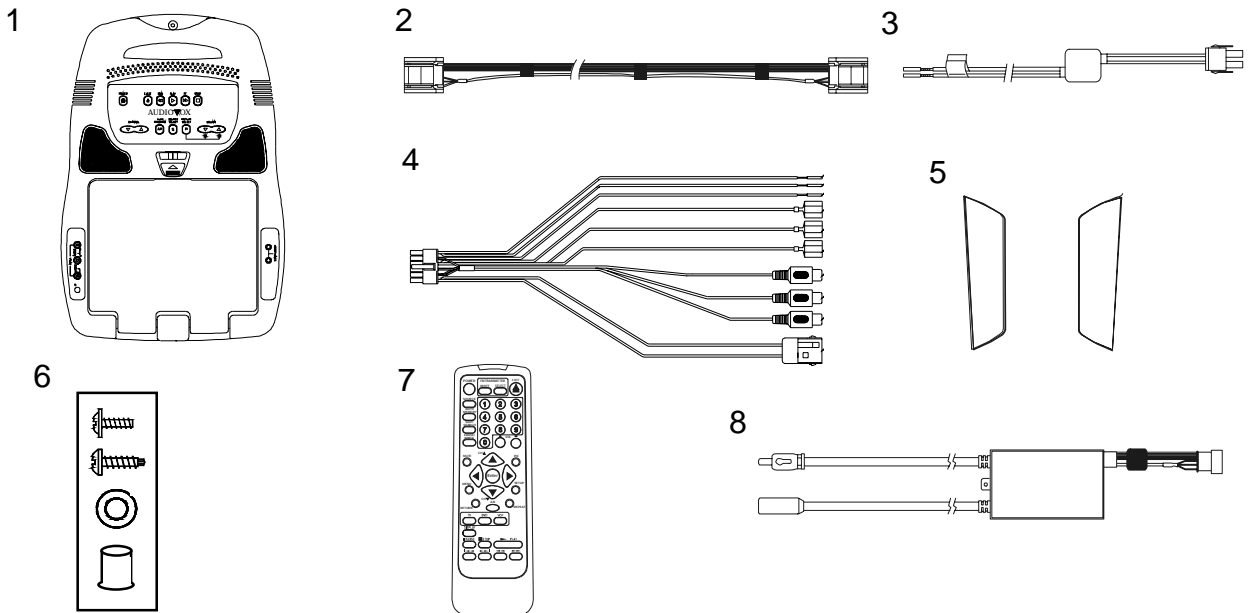

TOOLS REQUIRED:

- #2 Phillips Screwdriver
- #1 Phillips Screwdriver
- Utility or Razor Knife or Shears
- Wire Strippers
- Upholstery Hook Tool (for removal of panels as necessary)
- Electrical Tape
- Masking Tape
- Multimeter (to verify 12 volt DC and continuity: Do not use a test light or logic probe)
- Marker – to mark headliner
- Scribe (to mark trim ring if used)
- Misc. Electrical Connectors (to connect to vehicle power source. Requirements will vary from vehicle to vehicle)
- DVD (to verify system operation after installation)

GENERAL INSTALLATION APPROACH:

- 1) Decide upon system configuration and options that will be installed (i.e.: what components, Satellite Radio, VCP, Tuner, RF Modulator/external amp, remote headphones, 2nd VCP, etc.).
- 2) Review all manuals to become familiar with electrical requirements and hook ups.
- 3) Decide upon mounting locations of all components and method of mounting.
- 4) Prep the vehicle by removing any interior trim necessary to gain access to vehicle's wiring as well as all areas where interconnecting wire harnesses will need to be located. If any access holes need to be cut into the vehicle (headliner, other trim components etc.), this should be done now as well. (Refer to Page 3).
- 5) Route the wiring harnesses throughout the vehicle as necessary. (Refer to the Wiring Diagrams on pages 6 of this manual as well as the wiring instructions for the individual components and accessory options being installed). Be sure that all wiring is protected from sharp edges and is routed in such a manner that it will not be pinched when all components and interior trim are fully installed. Be sure to leave enough slack in the wiring at each component to allow working room.
- 6) Remove all A/V system components from their packaging and place them loosely in the vehicle at their respective locations.
- 7) Connect all components together (electrically) and verify proper operation of all system functions. Note: This is best done BEFORE, components have been permanently mounted.
- 8) After verifying proper operation of the system, proceed to mount of each component.
- 9) When all components are mounted, recheck function of entire system again to ensure that no wiring was pinched or connected improperly during final installation.

GENERAL SYSTEM CONFIGURATIONS:

The following is intended to provide some of the system configurations that are possible with the VOD808 Drop Down Video Systems:

System 1: Video Monitor with TV tuner (VOD808), with VCP .

- Optional Accessory Harness (P/N 8010730) must be purchased.
- Optional Wireless Headphones (P/N IR2CHS) must be purchased.
- TV antenna must be added (AN-300 or similar).

Notes: There are a few audio output options can be added as follows:

- a) Additional speakers can be added to a VOD808 system using the speaker outputs. Refer to the wiring diagram on p6.

The VOD808 video systems are only intended for an overhead, drop down installation. It is not intended for seat back or any other type of mounting. The hinging mechanism is designed for horizontal, drop down use only.

VEHICLE PREPARATION:

- 1) Locate an accessory power source (+12v when key is in the ACC. and run positions, and 0v when key is off), constant power source (+12 Vdc at all times). Also locate a good grounding point. Generally, these connection points can be found at the Ignition Switch, Fusebox, Radio etc.
- 2) The mounting method and location will vary from vehicle to vehicle, so this manual will only focus on the installation of the video monitor and related console accessories.
- 3) Generally, the best location for the video monitor is where the vehicle's factory dome light is installed. The monitor should be located in such a manner that it can be comfortably viewed by rear seat passengers. **NEVER INSTALL THE MONITOR IN A PLACE WITHIN THE DRIVER'S VIEW. THIS IS NOT ONLY DANGEROUS, BUT IT IS ALSO ILLEGAL IN MANY STATES.**
- 4) Once the mounting location of the monitor has been determined, there may be additional preparation work necessary, depending on the vehicle structure and installation method. Some of the steps that may be required are:
 - A) Removal of the vehicle's dome light
 - B) The headliner may need to be trimmed as per the drawing below.
 - C) If the mini-console will be used, it will have to be trimmed to fit the contour of the vehicle's headliner. Refer to the "Mini-Console installation" section in this manual.

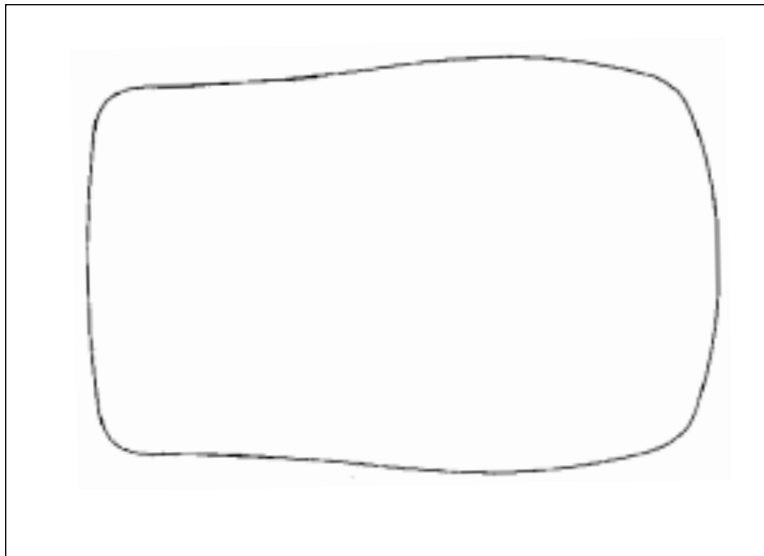

FULL SIZE CONSOLE INSTALLATION

There are several "full size" custom console available for selected vehicles. Some of these vehicles are the Chevrolet Suburban, Ford Expedition, and Dodge Durango. These full size consoles incorporate several additional features, and particularly useful if the vehicle you are installing this system into already has an OEM overhead console in the headliner.

Refer to the installation manual that comes with the console itself for complete installation instructions.

MINI CONSOLE INSTALLATION:

This page only covers special installation considerations for the mini-console installation.

If the video monitor is to be installed in a vehicle with the mini console, the console may need to be trimmed to fit the contour of the vehicle headliner.

- 1) In this installation, the video monitor is mounted directly to the overhead cross-member in the roof using the mounting screw bosses. These screw bosses should contact the cross-member directly (i.e.: no gap between the screw boss and the roof structure). Also, be sure that the screws do not pierce the outer roof skin when fully fastened to the cross-member. The mini-console is attached to the video monitor using the perimeter screw bosses. It is important that the screws used in this installation are not overtightened, and that the video monitor and mini-console are mounted in such a way that the assembly does not distort (or bend) when the mounting screws are tightened. An alternate method is to use a piece of plywood (12"x9"x3/4"). First secure the plywood block to the cross-member, then screw the monitor into the plywood. See the drawing on page 5.
- 2) It is best to mount the video monitor to the roof structure without the mini-console first. There should be a gap between the headliner and the outer flange of the video monitor. The mini-console should be cut to fill this gap. Apply masking tape to the outer surface of the mini-console in the areas where the cut will be made.
- 3) Mark the cut to follow the necessary contour of the roof. The suggested method of marking is as follows:
 - A) First mark the narrowest point of the mini-console on the masking tape. Be careful to consider not only vertical location, but fore-aft location.
 - B) Using the handle of a screwdriver, make a "transfer marking tool". See diagram below. Place the tool against the roof and the marker against the masking tape on the mini-console. Trace the cut to be made around the entire perimeter of the mini-console.
 - C) Cut the mini-console using a sharp utility knife or shears. Make the cut in several passes over the marked line, each time cutting a little deeper. It is not necessary to cut completely through the plastic, the cut only need be over 50% of the wall thickness of the plastic. By bending the cut back and forth several times, the plastic will break cleanly at the cut.
 - D) Check the fit of the trimmed console and make any minor adjustments necessary.
- 4) The mini-console can be painted or covered with a material that matches the headliner before assembling the mini-console to video monitor.
- 5) The finished mini-console should be attached to the video monitor, then attach the assembly to the roof.

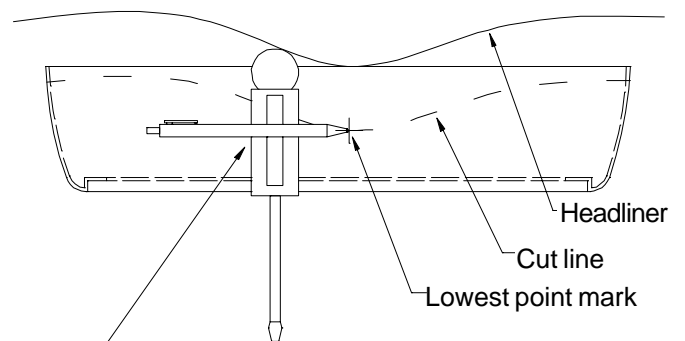

△ Tape marker to screwdriver. Starting at your mark for the lowest point, trace the contour of the roof

MOUNTING THE MINI-CONSOLE

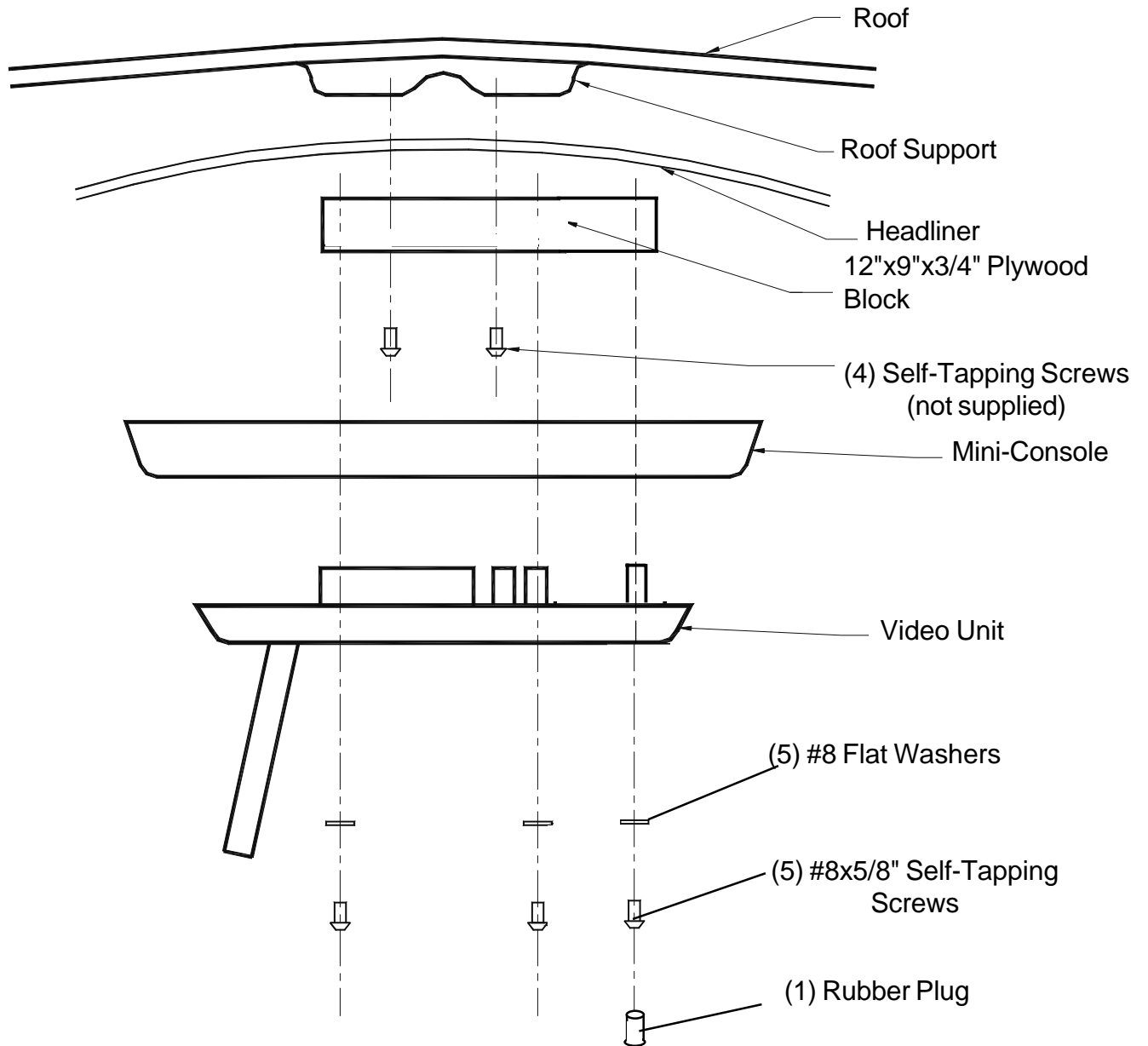

VOD808

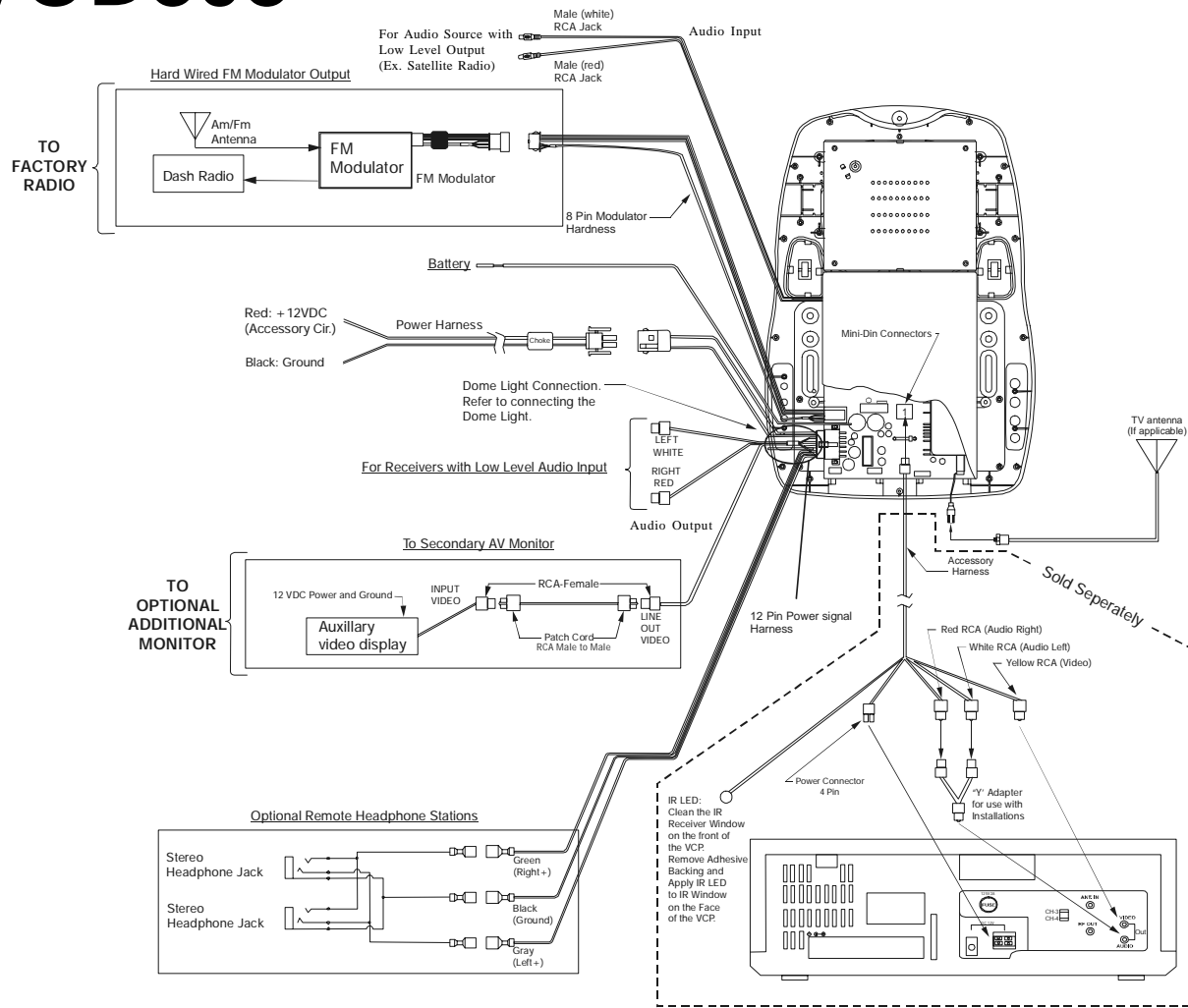

- 1) Make the connections to the vehicle for the 12 pin wiring harness.
- 2) When connecting an AV Component, insert the Circular Mini-Din Connector of the source component harness through the wire tie loop on the main PCB and into the Mini-Din Right Connector on the main PCB. Pull the wire tie loop tight and cut off the excess.
- 3) Connect power harness to vehicle electrical system by tapping into an accessory hot line, constant battery line and also a ground.
- 4) Connect 8 pin wiring harness from video monitor to the mating connector on FM Modulator.
- 5) Connect the FM Modulator to the Vehicle Radio.
- 6) Mount and connect the Television Antenna (sold separately).
- 7) Verify all functions of the System before final mounting of the finished assembly.

A/V Source Definitions:

- 1= TV Tuner
- 2= AV1 input (VCP, game or future DVD, etc)
- 3= AUX input (VCP, game or future DVD, etc)
- 4= Built -in DVD

CONNECTING THE DOME LIGHTS

The dome lights in the video monitor require three connections to the vehicle's wiring. There are two common types of dome light circuits used, positive or negative switched. Positive systems supply voltage to the interior lights to turn them on, negative switched systems apply ground to illuminate the bulbs. To determine which system you have you must locate the wires at the dome light. On a positive switched system, with all the doors closed and the lights out, both wires at the dome light will rest at ground. When the light is activated, one of these wires will switch to +12 vdc. This is the vehicle's switching wire. On a negative switched system, with all the doors closed and the lights out, both wires at the dome light will rest at +12vdc. When the light is activated, one of these wires will switch to ground. This is the switching wire. For positive systems, connect the purple / brown (Lamp auto) wire to the vehicle's switched wire. Then connect the red / black (lamp on) wire to a fused constant 12 volt source and the black / red (lamp common) wire to a good ground. Positive systems are commonly found on Ford vehicles. For negative systems, connect the purple / brown (Lamp auto) wire to the vehicle's switched wire. Then connect the red / black (lamp on) wire to a good ground and the black / red (lamp common) wire to fused constant 12 volt source. Negative systems are commonly found on General Motors and import vehicles.

NOTE:

Some vehicles which incorporate transistorized control of the dome light circuit, such as the 1999 Dodge Caravan, may require that the purple / brown (Lamp auto) wire be connected to the door pin switch wire, as the additional current draw of the Monitor's lights may not be supported by the output of the vehicles body control computer.

Positive Switched Dome lighting

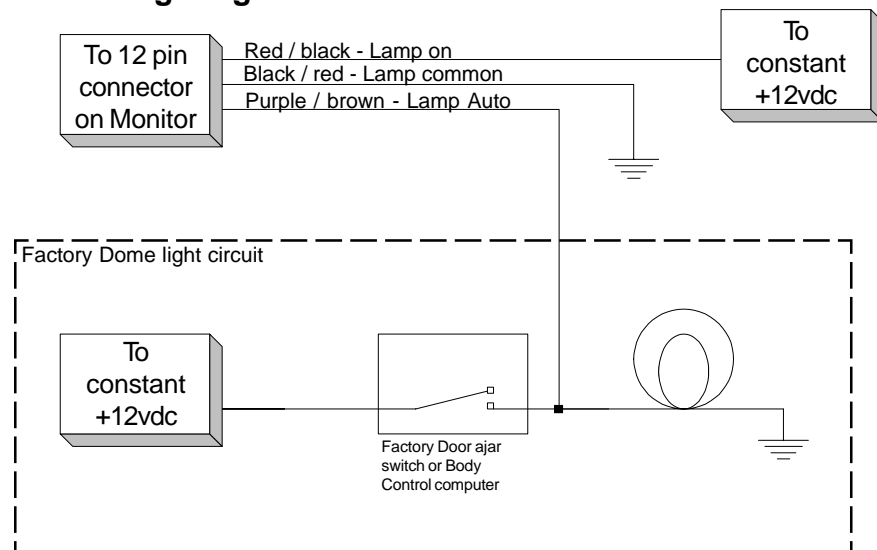

Negative Switched Dome lighting

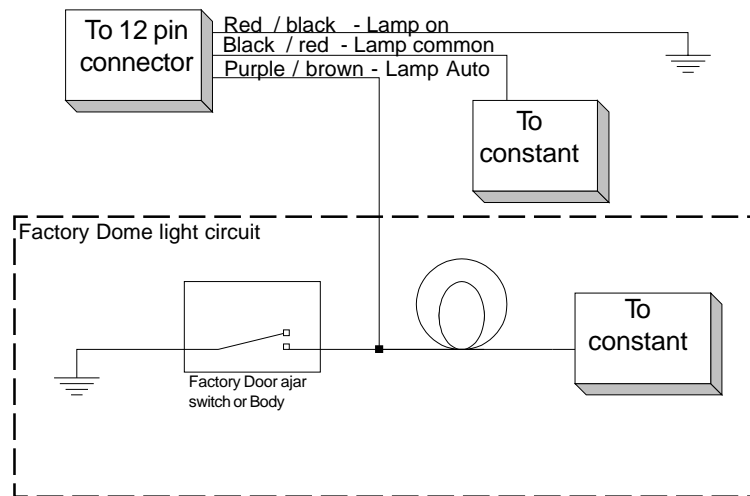

Troubleshooting:

SYMPTOM:

REMEDY:

No power at Video Monitor

-Verify +12 VDC on Red wire at 2 pin Power Harness behind video monitor. Verify ground connection with continuity test from known good ground to black wire at 2 pin Power Harness

Power but no video or sound

-Verify that the correct source is selected (i.e.:1,2,3 or 4). Verify that the source is on and playing a known good media (such as a DVD or videotape). Verify connections at both ends of the source component harness.

Picture, but no sound

-Push and hold the volume up button (▲) on the remote control until sound is heard over wired headphones. If problem is limited to the dash radio, verify radio is tuned to the correct frequency, and that power to the wired RF modulator is on. Otherwise, verify all connections per the wiring diagram on page 6 .

Static on TV Stations (Tuner Version Only)

-Press Auto Program button. Then press CH up or CH down. Verify antenna mounting and connections to the tuner.
Note: Due to the nature of TV signals, vehicle motion, direction the vehicle is facing, distance from the transmitter, nearby surroundings and weather may adversely affect TV reception. These conditions may result in the following: picture roll, "snowy" picture, or momentary loss of color.

No Infrared remote functions for VCP (or other components)

-Check batteries in the hand held remote. Verify that the IR LED (page 6 Wiring Diagram) is properly attached to the sensor window of the VCP (or other component).

This page blank intentionally



For Customer Service
Visit Our Website At
www.audiovox.com
Product Information, Photos,
FAQ's Owner's Manuals

128-6703

© Copyright 2003 Audiovox Electronics Corp. 150 Marcus Blvd. Hauppauge, NY 11788